



Sri Chaitanya IIT Academy., India

✦ A.P ✦ T.S ✦ Chandigarh ✦ Karnataka ✦ Tamilnadu ✦ Maharashtra ✦ Delhi ✦ Ranchi

Jee Main 2020(Sep)

04-Sep-2020 (Evening Shift)



Question Paper, Key and Solutions

Corporate Office : Plot # 304, Kaset ty Height s, Sri Ayyappa Societ y, Madhapur, Hyderabad – 500081,

Web : www.srichaitanya.net, Email: webmaster@srichaitanya.net, Our Call Center Timings : 9.30 AM to 6.30 PM (Mon – Sat)

Phone : 040-66151515, 040-66060606

Physics

(SINGLE CORRECT ANSWER TYPE)

This section contains 20 multiple choice questions. Each question has 4 options (1), (2), (3) and (4) for its answer, out of which ONLY ONE option can be correct.

Marking scheme: +4 for correct answer, 0 if not attempted and -1 in all other cases.

1. The driver of a bus approaching a big wall notices that the frequency of his bus's horn changes from 420 Hz to 490 Hz when he hears it after it gets reflected from the wall. Find the speed of the bus if speed of the sound is 330 m s^{-1}
1. 91 km h^{-1} 2. 61 km h^{-1} 3. 71 km h^{-1} 4. 81 km h^{-1}

Key: 1

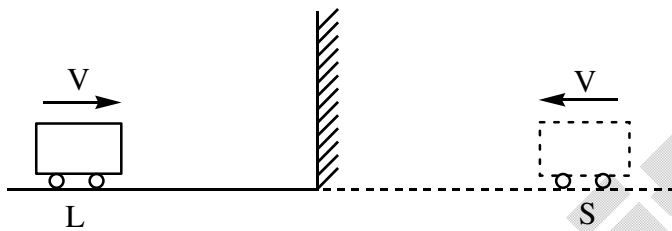

Sol:

$$f_e = f_0 \left\{ \frac{C+V}{C-V} \right\} \Rightarrow \frac{490}{420} = \frac{1+V/C}{1-V/C}$$

$$\Rightarrow V = \frac{330}{13} \text{ m/s} = 91.38 \frac{\text{km}}{\text{h}} \approx 91 \frac{\text{km}}{\text{h}}$$

2. In a photoelectric effect experiment, the graph of stopping potential V versus reciprocal of wavelength obtained is shown in the figure. As the intensity of incident radiation is increased:

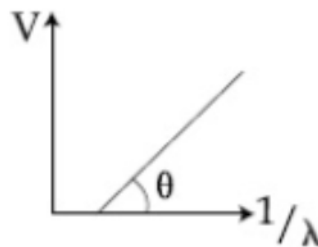

1. Graph does not change
2. Slope of the straight line get more steep
3. Straight line shifts to left
4. Straight line shifts to right

Key: 1

Corporate Office : Plot # 304, Kasetty Heights, Sri Ayyappa Society, Madhapur, Hyderabad – 500081,

Web : www.srichaitanya.net, Email: webmaster@srichaitanya.net, Our Call Center Timings : 9.30 AM to 6.30 PM (Mon – Sat)

Phone : 040-66151515, 040-66060606

Sol: $\frac{hc}{\lambda} = \phi + eV$

$$\Rightarrow V = \left(\frac{hc}{e}\right)\frac{1}{\lambda} - \frac{\phi}{e}$$

Slope $\left(\frac{hc}{e}\right)$ and intercept $\left(-\frac{\phi}{e}\right)$, both are independent of intensity of incident radiation.

3. A particle of charge q and mass m is subjected to an electric field $E = E_0(1 - ax^2)$ in the x -direction, where a and E_0 are constants. Initially the particle was at rest at $x = 0$. Other than the initial position the kinetic energy of the particle becomes zero when the distance of the particle from the origin is:

1. $\sqrt{\frac{1}{a}}$ 2. $\sqrt{\frac{3}{a}}$ 3. $\sqrt{\frac{2}{a}}$ 4. a

Key: 2

Sol: From work-energy theorem

$$dK = dW = qEdx = qE_0(1 - ax^2)dx$$

$$\therefore \Delta k = qE_0 \int_0^x (1 - ax^2) dx \Rightarrow x - \frac{ax^3}{3} = 0$$

$$\Rightarrow x \left(1 - \frac{a}{3}x^2\right) = 0 \Rightarrow x = 0, \pm \sqrt{\frac{3}{a}}$$

4. A paramagnetic sample shows a net magnetization of 6 A/m when it is placed in an external magnetic field of 0.4 T at a temperature of 4 K. When the sample is placed in an external magnetic field of 0.3 T at a temperature of 24 K, then the magnetization will be:

1. 0.75 A/m 2. 2.25 A/m 3. 1 A/m 4. 4 A/m

Key: 1

Sol: Curie's law : $x_m \propto \frac{1}{T} \Rightarrow \frac{I}{H} \propto \frac{1}{T}$

$$\Rightarrow \frac{I_1 T_1}{H_1} = \frac{I_2 T_2}{H_2} \Rightarrow \frac{6 \times 4}{0.4} = \frac{I_2 \times 24}{0.3}$$

$$\Rightarrow I_2 = 0.75$$

5. A body is moving in a low circular orbit about a planet of mass M and radius R . The radius of the orbit can be taken to be R itself. Then the ratio of the speed of this body in the orbit to the escape velocity from the planet is:

1. 1 2. $\frac{1}{\sqrt{2}}$ 3. 2 4. $\sqrt{2}$

Key: 2

Sol: $V_0 = \sqrt{\frac{GM}{R}}$ $V_e = \sqrt{\frac{2GM}{R}}$ $\therefore \frac{V_0}{V_e} = \frac{1}{\sqrt{2}}$

6. A person pushes a box on a rough horizontal platform surface. He applies a force of 200 N over a distance of 15 m. Thereafter, he gets progressively tired and his applied force reduces linearly with distance to 100 N. The total distance through which the box has been moved is 30 m. What is the work done by the person during the total movement of the box?

1. 5250 J 2. 5690 J 3. 2780 J 4. 3280 J

Key: 1

Sol:

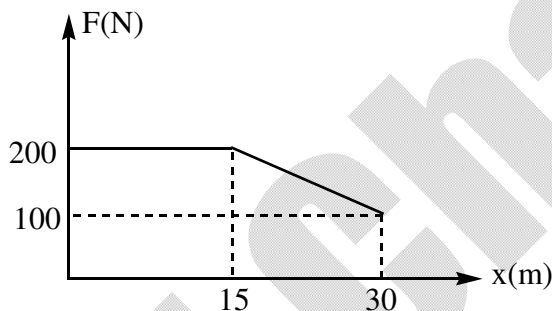

\therefore Work done = Area under curve

$$= 200 \times 15 + \left(\frac{200 + 100}{2} \right) 15$$

$$= 3000 + 2250$$

$$= 5250 \text{ J}$$

7. A capacitor C is fully charged with voltage V_0 . After disconnecting the voltage source, it is connected in parallel with another uncharged capacitor of capacitance $\frac{C}{2}$. The energy loss in the process after the charge is distributed between the two capacitors is:

1. $\frac{1}{2}CV_0^2$ 2. $\frac{1}{3}CV_0^2$ 3. $\frac{1}{6}CV_0^2$ 4. $\frac{1}{4}CV_0^2$

Key: 3

Sol:

$$\begin{aligned} \text{Heat loss} &= \frac{1}{2} \left(\frac{C_1 C_2}{C_1 + C_2} \right) V_0^2 \\ &= \frac{1}{2} \times \frac{C}{3} \times V_0^2 = \frac{1}{6} C V_0^2 \end{aligned}$$

8. A series L-R circuit is connected to a battery of emf V . If the circuit is switched on at $t = 0$, then the time at which the energy stored in the inductor reaches $\left(\frac{1}{n}\right)$ times of its maximum value, is:

1. $\frac{L}{R} \ln\left(\frac{\sqrt{n}-1}{\sqrt{n}}\right)$ 2. $\frac{L}{R} \ln\left(\frac{\sqrt{n}+1}{\sqrt{n}-1}\right)$ 3. $\frac{L}{R} \ln\left(\frac{\sqrt{n}}{\sqrt{n}+1}\right)$ 4. $\frac{L}{R} \ln\left(\frac{\sqrt{n}}{\sqrt{n}-1}\right)$

Key: 4

Sol: $i = i_0 \{1 - e^{-Rt/L}\}$

$$U = \frac{1}{2} Li^2 \quad \Rightarrow \quad U = U_0 (1 - e^{-Rt/L})^2$$

$$\Rightarrow (1 - e^{-Rt/L})^2 = \frac{1}{n} \quad \Rightarrow \quad 1 - e^{-Rt/L} = \frac{1}{\sqrt{n}}$$

$$\Rightarrow e^{Rt/L} = \frac{\sqrt{n}}{\sqrt{n}-1} \quad \Rightarrow \quad t = \frac{L}{R} \ln\left(\frac{\sqrt{n}}{\sqrt{n}-1}\right)$$

9. Match the thermodynamic processes taking place in a system with the correct conditions. In the table : ΔQ is the heat supplied, ΔW is the work done and ΔU is change in internal energy of the system.

Process		Condition	
(I)	Adiabatic	(A)	$\Delta W = 0$
(II)	Isothermal	(B)	$\Delta Q = 0$
(III)	Isochoric	(C)	$\Delta U \neq 0, \Delta W \neq 0, \Delta Q \neq 0$
(IV)	Isobaric	(D)	$\Delta U = 0$

- (I) – (A), (II) – (B), (III) – (D), (IV) – (D)
- (I) – (B), (II) – (A), (III) – (D), (IV) – (C)
- (I) – (B), (II) – (D), (III) – (A), (IV) – (C)
- (I) – (A), (II) – (A), (III) – (B), (IV) – (C)

Key: 3

Sol:

Adiabatic : $\Delta Q = 0$ Isothermal : $\Delta U = 0$ Isochoric : $\Delta W = 0$ Isobaric : $\Delta Q \neq 0, \Delta U \neq 0, \Delta W \neq 0$

10.

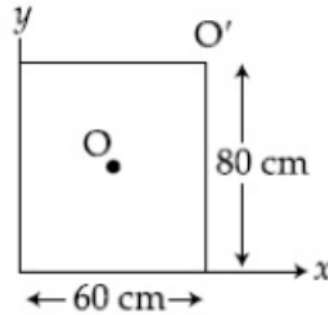

For a uniform rectangular sheet shown in the figure, the ratio of moments of inertia about the axes perpendicular to the sheet and passing through O (the centre of mass) and O' (corner point) is:

1. $2/3$ 2. $1/2$ 3. $1/4$ 4. $1/8$

Key: 3

Sol:

$$I_0 = \frac{1}{12} m(a^2 + b^2) \quad I_0' = \frac{1}{3} m(a^2 + b^2) \quad \therefore \frac{I_0'}{I_0} = \frac{1/12}{1/3} = \frac{1}{4}$$

11. Two identical cylindrical vessels are kept on the ground and each contain the same liquid of density d . The area of the base of both vessels is S but the height of liquid in one vessel is x_1 and in the other, x_2 . When both cylinders are connected through a pipe of negligible volume very close to the bottom, the liquid flows from one vessel to the other until it comes to equilibrium at a new height. The change in energy of the system in the process is

1. $\frac{1}{4}gdS(x_2 - x_1)^2$ 2. $gdS(x_2 + x_1)^2$ 3. $gdS(x_2^2 + x_1^2)$ 4. $\frac{3}{4}gdS(x_2 - x_1)^2$

Key: 1

Sol:

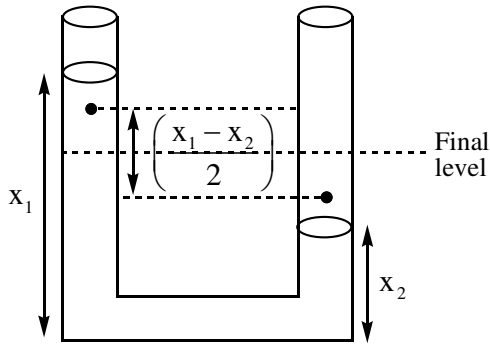

$$\Delta U = \Delta mg \Delta y_c$$

$$= -\frac{1}{2} dgs(x_1 - x_2) \times \frac{(x_1 - x_2)}{2} = -\frac{1}{4} dgs(x_1 - x_2)^2$$

12. Identify the operation performed by the circuit given below:

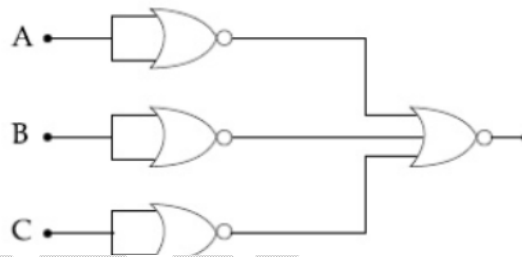

1. NOT 2. OR 3. AND 4. NAND

Key: 3

Sol:

$$\overline{(A + A)} + \overline{(B + B)} + \overline{(C + C)}$$

$$= \overline{A} + \overline{B} + \overline{C} = A \cdot B \cdot C$$

Hence, AND GATE

13. The value of current i_1 flowing from A to C in the circuit diagram is:

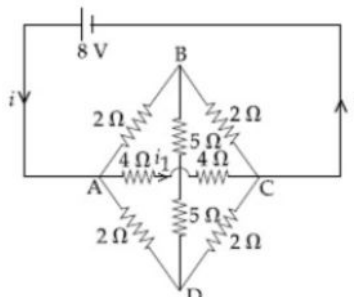

1. 1 A 2. 5A 3. 4 A 4. 2 A

Key: 1

Sol:

$$i_1 = \frac{8}{4+4} = 1A$$

14. The electric field of a plane electromagnetic wave is given by

$$\vec{E} = E_0(\hat{x} + \hat{y})\sin(kz - \omega t)$$

Its magnetic field will be given by:

- | | |
|--|---|
| 1. $\frac{E_0}{c}(\hat{x} + \hat{y})\sin(kz - \omega t)$ | 2. $\frac{E_0}{c}(-\hat{x} + \hat{y})\sin(kz - \omega t)$ |
| 3. $\frac{E_0}{c}(\hat{x} - \hat{y})\sin(kz - \omega t)$ | 4. $\frac{E_0}{c}(\hat{x} - \hat{y})\cos(kz - \omega t)$ |

Key: 2

Sol:

\vec{B} will have same phase as \vec{E} and $\vec{E} \times \vec{B}$ will be along \vec{C}

$$\text{Also, } B_0 = \frac{E_0}{C} \quad \therefore \vec{B} = \frac{E_0}{C}(-\hat{x} + \hat{y})\sin(kz - \omega t)$$

15. A small ball of mass m is thrown upward with velocity u from the ground. The ball experiences a resistive force mkv^2 where v is its speed. The maximum height attained by the ball is:

- | | |
|---|---|
| 1. $\frac{1}{2k} \tan^{-1} \frac{ku^2}{g}$ | 2. $\frac{1}{k} \ln \left(1 + \frac{ku^2}{2g} \right)$ |
| 3. $\frac{1}{2k} \ln \left(1 + \frac{ku^2}{g} \right)$ | 4. $\frac{1}{k} \tan^{-1} \frac{ku^2}{2g}$ |

Key: 3

Sol:

$$V \frac{dV}{dy} = -g - kV^2 \Rightarrow \int_u^0 \frac{VdV}{g + kV^2} = -\int_0^H dy$$

$$\Rightarrow H = \frac{1}{2k} \ln \left(1 + \frac{ku^2}{g} \right)$$

16. Find the Binding energy per nucleon for ${}_{50}^{120}\text{Sn}$. Mass of proton $m_p = 1.00783\text{U}$, mass of neutron $m_n = 1.00867\text{U}$ and mass of tin nucleus $m_{\text{Sn}} = 119.902199\text{U}$. (take $1\text{U} = 931\text{MeV}$)
1. 8.5 MeV 2. 8.0 MeV 3. 7.5 MeV 4. 9.0 MeV

Key: 1

Sol:

$$E_{\text{in}} = (50 \times 1.00783 + 70 \times 1.00867 - 119.902199) \frac{931}{120} = 8.50\text{ MeV}$$

17. A circular coil has moment of inertia 0.8 kg m^2 around any diameter and is carrying current to produce a magnetic moment of 20 Am^2 . The coil is kept initially in a vertical position and it can rotate freely around a horizontal diameter. When a uniform magnetic field of 4 T is applied along the vertical, it starts rotating around its horizontal diameter. The angular speed the coil acquires after rotating by 60° will be:
1. 10 rad s^{-1} 2. $10\pi\text{ rad s}^{-1}$ 3. $20\pi\text{ rad s}^{-1}$ 4. 20 rad s^{-1}

Key:

Sol:

Applying conservation of energy :

$$\frac{1}{2} I \omega^2 = MB \{ \cos \theta_f - \cos \theta_i \}$$

$$\Rightarrow \frac{1}{2} \times 0.8 \times \omega^2 = 20 \times 4 \left(\frac{\sqrt{3}}{2} \right)$$

$$\Rightarrow \omega = 10 \times 3^{1/4}$$

No matching keys

18. A quantity x is given by (Fv^2 / WL^4) in terms of moment of inertia I , force F , velocity v , work W and length L . The dimensional formula for x is same as that of:
1. Planck's constant 2. Energy density
3. force constant 4. Coefficient of viscosity

Key: 2

Sol:

$$\left[\frac{1}{2} \rho v^2 \right] = \frac{[ML^2][MLT^{-2}][LT^{-1}]^2}{[ML^2T^{-2}][L]^4}$$

$$= [ML^{-1}T^{-2}]$$

$$= [\text{Energy density}]$$

19. A cube of metal is subjected to a hydrostatic pressure of 4 GPa. The percentage change in the length of the side of the cube is close to :

(Given bulk modulus of metal, $B = 8 \times 10^{10}$ Pa)

1. 5 2. 1.67 3. 20 4. 0.6

Key: 2

Sol:

$$-\frac{\Delta V}{V} = \frac{\Delta P}{B}$$

$$\Rightarrow -3 \frac{\Delta \ell}{\ell} = \frac{\Delta P}{B}$$

$$\Rightarrow \frac{\Delta \ell}{\ell} = \frac{1}{3} \frac{\Delta P}{B} = \frac{1}{3} \times \frac{4 \times 10^9}{8 \times 10^{10}}$$

$$= 1.67\%$$

20. Consider two uniform discs of the same thickness and different radii $R_1 = R$ and $R_2 = \alpha R$ made of the same material. If the ratio of their moments of inertia I_1 and I_2 , respectively, about their axes is $I_1 : I_2 = 1 : 16$ then the value of α is:

1. 2 2. $2\sqrt{2}$ 3. $\sqrt{2}$ 4. 4

Key: 1

Sol:

$$I \propto mR^2$$

$$\propto (\sigma R^2)R^2$$

$$\Rightarrow I \propto R^4$$

$$\therefore \frac{R_2}{R_1} = \left(\frac{I_2}{I_1} \right)^{1/4} = (16)^{1/4}$$

$$\Rightarrow \alpha = 2$$

(NUMERICAL VALUE TYPE)

This section contains 5 questions. Each question is numerical value. For each question, enter the correct numerical value (in decimal notation, truncated/rounded-off to second decimal place, (e.g. 6.25, 7.00, -0.33, -.30, 30.27, -127.30).

Marking scheme: +4 for correct answer, 0 if not attempted and 0 in all other cases.

21. Orange light of wavelength 6000×10^{-10} m illuminates a single slit of width 0.6×10^{-4} m. The maximum possible number of diffraction minima produced on both sides of the central maximum is

Key: 198

Sol:

For minima $d \sin \theta = n \lambda$

$$\Rightarrow \sin \theta = \frac{n \lambda}{d} < 1 \quad \Rightarrow n < \frac{d}{\lambda} = \frac{0.6 \times 10^{-4}}{6000 \times 10^{-10}} = 100$$

22. The distance between an object and a screen is 100 cm. A lens can produce real image of the object on the screen for two different positions between the screen and the object. The distance between these two positions is 40 cm. If the power of the lens is close to $\left(\frac{N}{100}\right)D$ where N is an integer, the value of N is _____

Key: 476

Sol: $f = \frac{D^2 - d^2}{4D} = \frac{100^2 - 40^2}{4 \times 100} = 21 \text{ cm} \quad \therefore P = \frac{100}{21} D$

$$\frac{N}{100} = \frac{100}{21} \quad N = 476$$

23. The speed versus time graph for a particle is shown in the figure. The distance travelled (in m) by the particle during the time interval $t = 0$ to $t = 5$ s will be _____

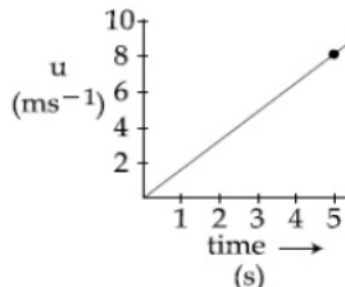

Key: 20

Sol: Distance travelled $= \frac{1}{2} \times 5 \times 8 = 20 \text{ m}$

24.

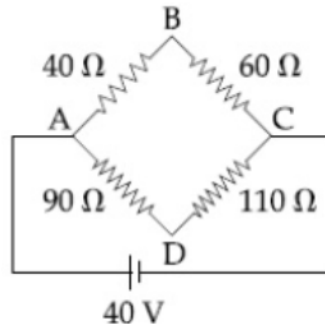

Four resistance 40Ω , 60Ω , 90Ω and 110Ω make the arms of a quadrilateral ABCD. Across AC is a battery of emf 40 V and internal resistance negligible. The potential difference across BD is V is _____

Key: 2

Sol:

$$V_D - V_B = 40 \times \frac{9}{20} - 40 \times \frac{4}{10} = 2 \text{ V}$$

25. The change in the magnitude of the volume of an ideal gas when a small additional pressure ΔP is applied at a constant temperature, is the same as the change when the temperature is reduced by a small quantity ΔT at constant pressure. The initial temperature and pressure of the gas were 300 K and 2 atm , respectively. If $|\Delta T| = C|\Delta P|$ then value of C in (K/atm) is

Key: 150

Sol:

At constant temperature $PV = nRT$
 $P\Delta V + V\Delta P = 0$

$$\Rightarrow \Delta V = -V \frac{\Delta P}{P}$$

At constant pressure $\frac{V}{T} = \frac{nR}{P}$

$$\Rightarrow \Delta V = V \cdot \frac{\Delta T}{T}$$

$$\therefore V \frac{\Delta T}{T} = V \frac{\Delta P}{P} \Rightarrow \frac{\Delta T}{\Delta P} = \frac{T}{P} = \frac{300}{2} = 150$$

CHEMISTRY**(SINGLE CORRECT ANSWER TYPE)**

This section contains 20 multiple choice questions. Each question has 4 options (1), (2), (3) and (4) for its answer, out of which ONLY ONE option can be correct.

Marking scheme: +4 for correct answer, 0 if not attempted and -1 in all other cases.

1. In the following reaction sequence, [C] is :

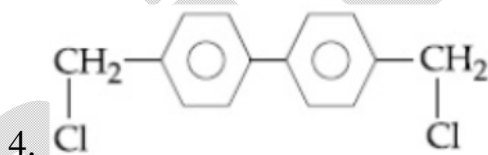
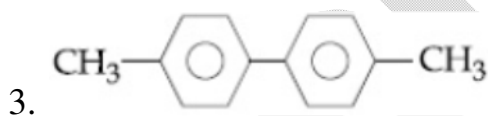
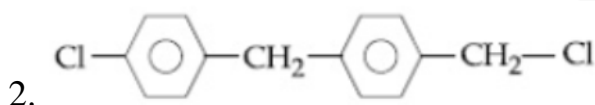
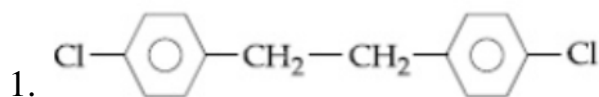
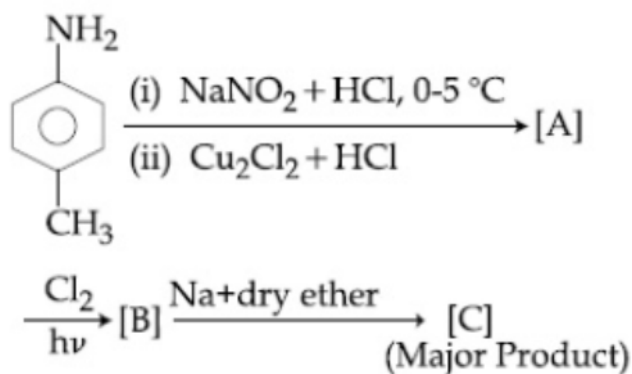

Key: 1

Sol:

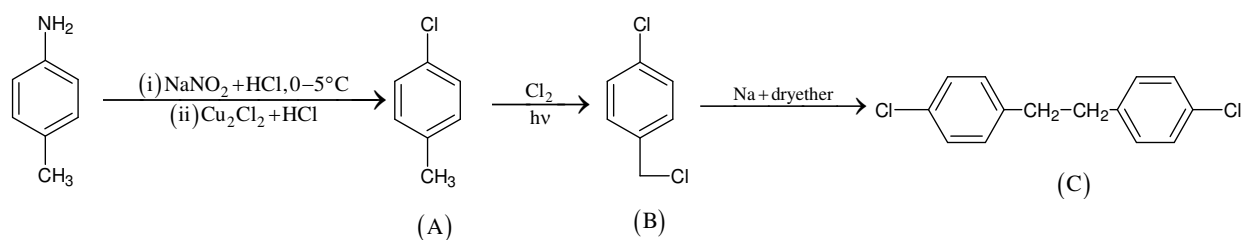

2. The molecule in which hybrid MOs involve only one d-orbital of the central atom is :

1. XeF_4 2. BrF_3 3. $[\text{Ni}(\text{CN})_4]^{2-}$ 4. $[\text{CrF}_6]^{3-}$

Key: 3

Sol:

The molecule in which hybrid MOs involve only one d-orbital of the central atom is $[\text{Ni}(\text{CN})_4]^{2-}$ as in this complex Ni^{2+} undergoes dsp^2 hybridization

3. Among the following compounds, which one has the shortest C – Cl bond?

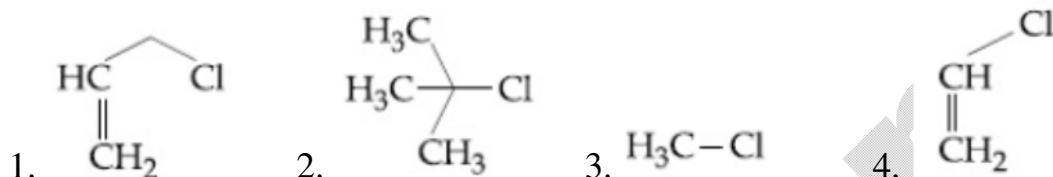

Key: 4

Sol:

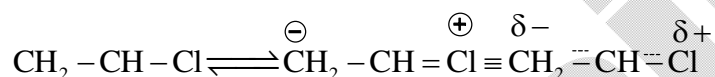

Due to resonance in (4) C-Cl bond length is shortest.

4. 250 mL of a waste solution obtained from the workshop of a goldsmith contains 0.1 M AgNO_3 and 0.1 M AuCl . The solution was electrolyzed at 2 V by passing a current of 1 A for 15 minutes. The metal / metals electrodeposited will be:

$$\left(E_{\text{Ag}^+/\text{Ag}}^0 = 0.80\text{V}, E_{\text{Au}^+/\text{Au}}^0 = 1.69\text{V} \right)$$

1. only silver
2. silver and gold in equal mass proportion
3. silver and gold in proportion to their atomic weights
4. only gold

Key: 3

Sol:

$$\frac{W_{\text{Au}}}{W_{\text{Ag}}} = \frac{Z_{\text{Au}}(Q)}{Z_{\text{Ag}}(Q)} = \frac{\frac{\text{Atomic mass of Gold}}{\text{Valency of gold}}}{\frac{\text{Atomic mass of silver}}{\text{Valency of silver}}}$$

5. Which of the following compounds will form the precipitate with aq. AgNO_3 solution most readily ?

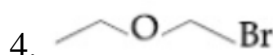
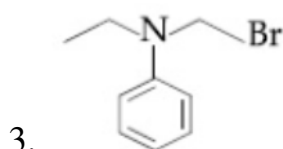
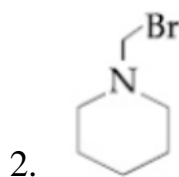
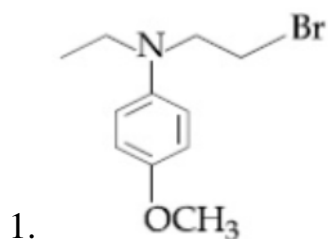

Key: 2

Sol:

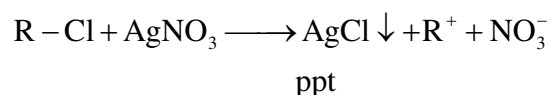

So one which will form most stable carbocation will give ppt with AgNO_3 most readily.

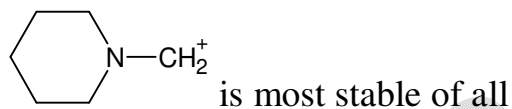

6. The process that is NOT endothermic in nature is:

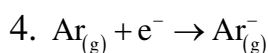
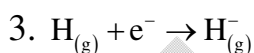
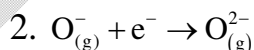
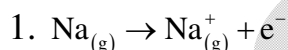

Key: 3

Sol:

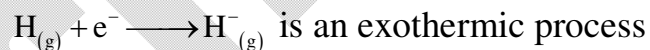

7. The Crystal Field Stabilization Energy (CFSE) of $[\text{CoF}_3(\text{H}_2\text{O})_3]$ ($\Delta_0 < P$) is:

1. $-0.4\Delta_0 + P$

2. $-0.4\Delta_0$

3. $-0.8\Delta_0$

4. $-0.8\Delta_0 + 2P$

Key: 2

Sol:

In $[\text{CoF}_3(\text{H}_2\text{O})_3]$, the Co^{3+} has d^6 configuration and the given complex is outer orbital type. So the electrons arrangement in d-orbitals is $t_{2g}^4 e_g^2$

Crystal field stabilization energy

$$= 4(-0.4\Delta_0) + 2(0.6\Delta_0)$$

$$= -0.4\Delta_0$$

Here the man pairing energy is not accounted as the original d^6 also has 1 pair of electrons.

8. The incorrect statement(s) among (a) – (c) is (are) :

(a) W(VI) is more stable than Cr(VI).

(b) in the presence of HCl, permanganate titrations provide satisfactory results.

(c) some lanthanoid oxides can be used as phosphors.

1. (a) and (b) only

2. (b) and (c) only

3. (b) only

4. (a) only

Key: 3

Sol:

a) W(VI) is more stable than Cr(VI) is correct as going down the group, stability of higher oxidation state increases in case of d-block elements.

b) is wrong as permanganate can oxidise HCl

c) is correct as some lanthanoid oxides are used as phosphors

9. A sample of red ink (a colloidal suspension) is prepared by mixing eosin dye, egg white, HCHO and water. The component which ensures stability of the ink sample is:

1. Eosin dye

2. HCHO

3. Egg white

4. Water

Key: 3

Sol:

Egg white contain Albumin which is a lyophylic colloid which ensures stability of the ink sample.

10. The mechanism of action of "Terfenadine" (Seldane) is:

1. Inhibits the action of histamine receptor
2. Activates the histamine receptor
3. Inhibits the secretion of histamine
4. Helps in the secretion of histamine

Key: 1

Sol:

Seldane, act as antihistamines. They interfere with the natural action of histamine for binding sites of receptor where histamine exerts its effect.
NCERT XII page 444.

11. If the equilibrium constant for $A \rightleftharpoons B + C$ is $K_{eq}^{(1)}$ and that of $B + C \rightleftharpoons P$ is $K_{eq}^{(2)}$, the equilibrium constant for $A \rightleftharpoons P$ is :

1. $K_{eq}^{(1)}K_{eq}^{(2)}$
2. $K_{eq}^{(1)} / K_{eq}^{(2)}$
3. $K_{eq}^{(2)} - K_{eq}^{(1)}$
4. $K_{eq}^{(1)} + K_{eq}^{(2)}$

Key: 1

Sol: Question ID:40503611258

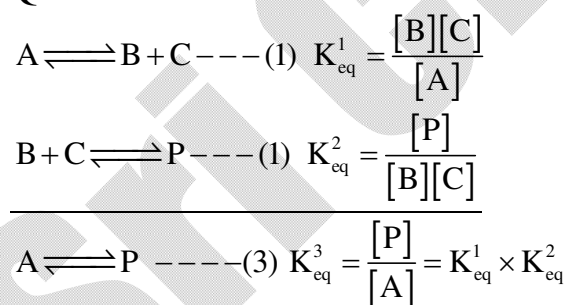

12. Five moles of an ideal gas at 1 bar and 298 K is expanded into vacuum to double the volume. The work done is:

1. $C_v(T_2 - T_1)$
2. $-RT(V_2 - V_1)$
3. $-RT \ln V_2 / V_1$
4. zero

Key: 4

Sol:

$$W = -P_{\text{ext}} (V_F - V_I)$$

$$P_{\text{ext}} = 0$$

$$W = 0$$

13. An alkaline earth metal 'M' readily forms water soluble sulphate and water insoluble hydroxide. Its oxide MO is very stable to heat and does not have rock-salt structure. M is:

1. Be 2. Sr 3. Ca 4. Mg

Key: 1

Sol:

Water soluble sulphate and water insoluble hydroxide is 'Be'. BeO does not have rock-salt structure.

14. The major product [R] in the following sequence of reactions is:

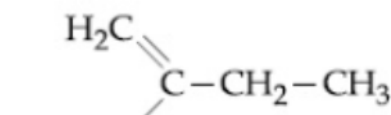
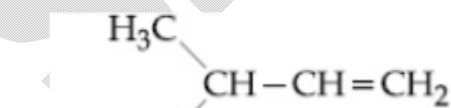
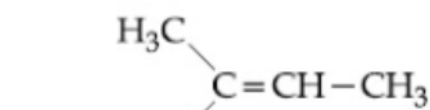
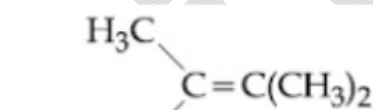
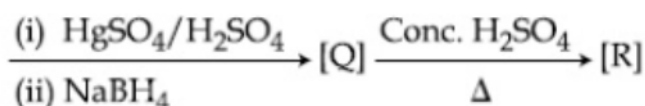
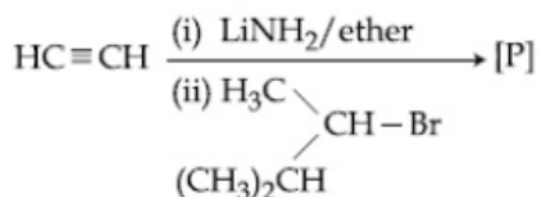

Key: 1

Sol:

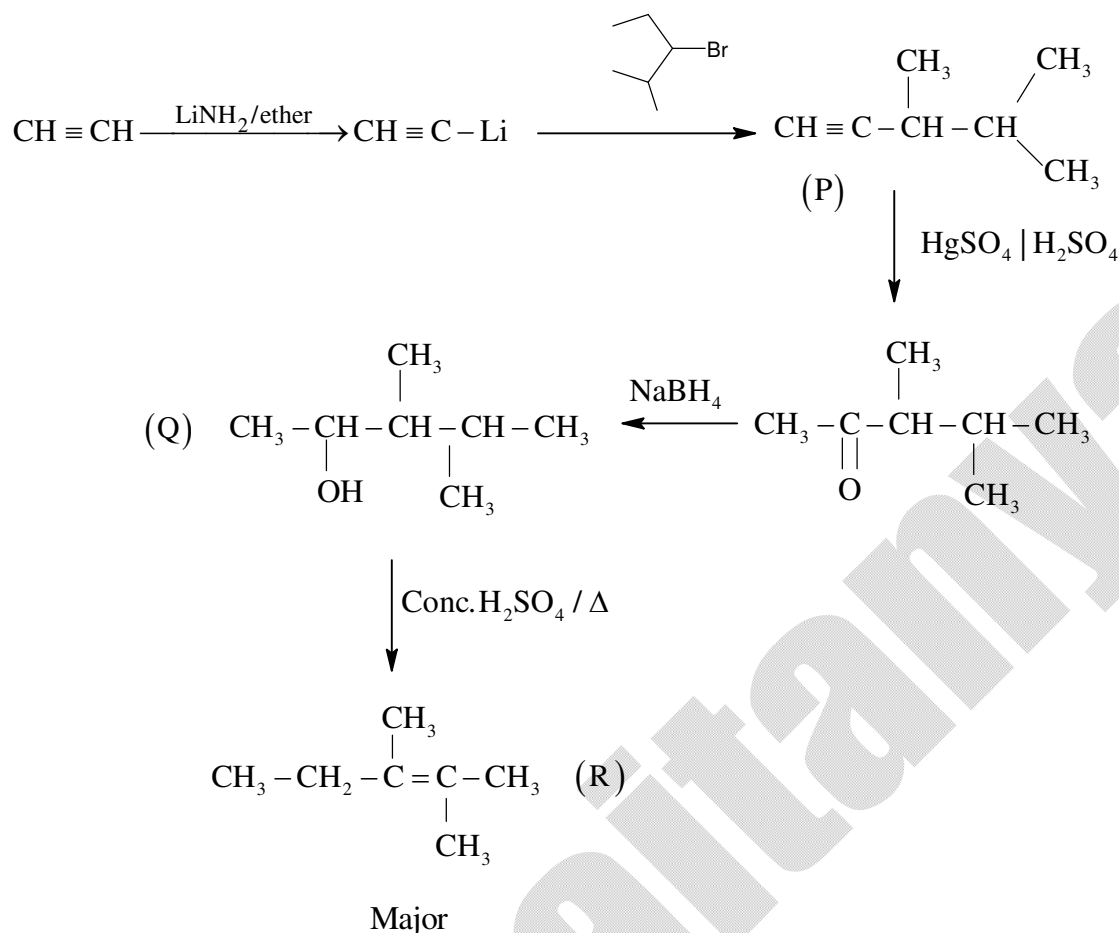

15. The processes of calcinations and roasting in metallurgical industries, respectively, can lead to :

1. Photochemical smog and global warming
2. Global warming and photochemical smog
3. Global warming and acid rain
4. Photochemical smog and ozone layer depletion

Key:

Sol: The process of calcinations and roasting in metallurgical industries respectively, can lead to release of SO_2 gas which causes global warming and acid rain.

16. The reaction in which the hybridization of the underlined atom is affected is :

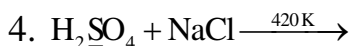
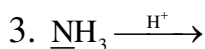
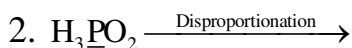
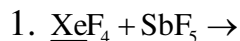

Key: 1

Sol:

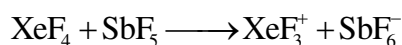

In XeF_4 ; Xe has sp^3d^2 hybridization

In XeF_3^+ ; Xe has sp^3d hybridization

17. The major product [C] of the following reaction sequence will be:

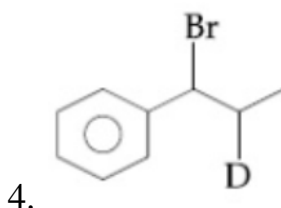
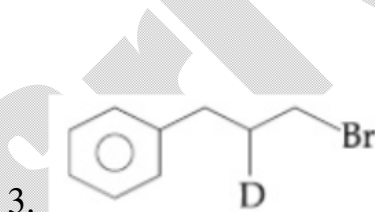
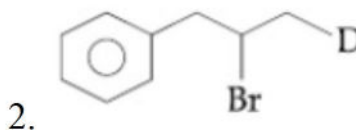
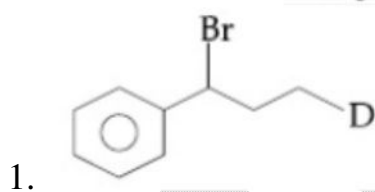
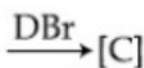
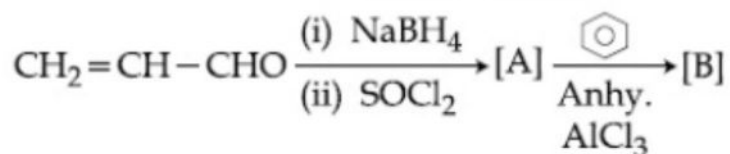

Key: 1

Sol:

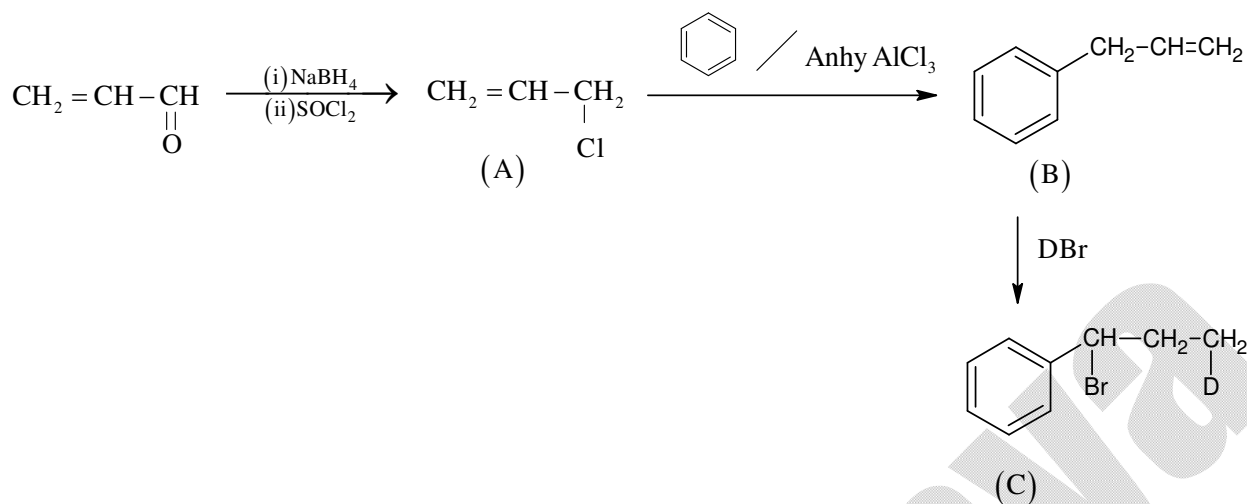

18. The one that can exhibit highest paramagnetic behaviour among the following is:

gly = glycinato; bpy = 2, 2'-bipyridine

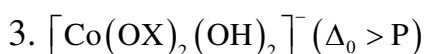
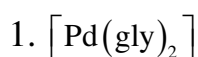

Key: 1

Sol:

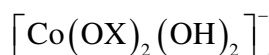
OX is $\text{C}_2\text{O}_4^{2-}$

So the charge on Co is +5

 Co^{+5} has $3d^4$ configuration with $\Delta_0 > p$; d^4 has t_{2g}^4 arrangement is two unpaired e^- s(3) In $[\text{Ti}(\text{NH}_3)_6]^{3+}$; Ti^{3+} has d configuration, Number of unpaired electrons=119. The shortest wavelength of H atom in the Lyman series is λ_1 . The longest wavelength in the Balmer series of He^+ is :

1. $\frac{36\lambda_1}{5}$

2. $\frac{27\lambda_1}{5}$

3. $\frac{5\lambda_1}{9}$

4. $\frac{9\lambda_1}{5}$

Key: 4

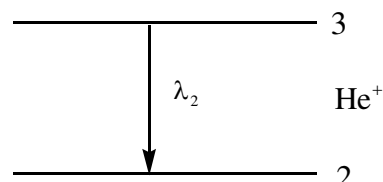
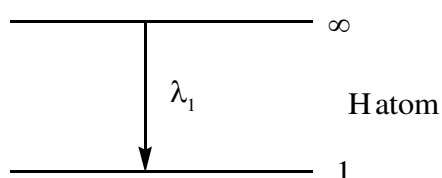

Sol:

$$\frac{1}{\lambda_1} = R_H (1)^2 \left[\frac{1}{1} \right]$$

$$\frac{1}{\lambda_2} = R_H (4)^2 \left[\frac{1}{4} - \frac{1}{9} \right]$$

$$\frac{1}{\lambda_2} = R_H \left(\frac{5}{9} \right) \quad \frac{1}{\lambda_2} = \frac{1}{\lambda_1} \left(\frac{5}{9} \right)$$

$$\lambda_2 = \frac{9\lambda_1}{5}$$

20. The major product [B] in the following reactions is :

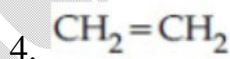
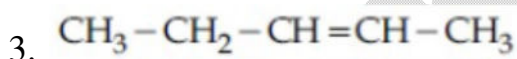
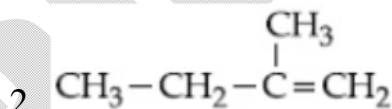
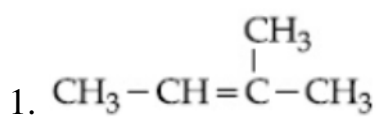
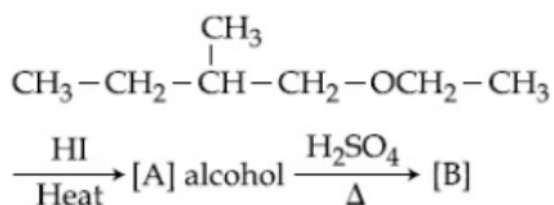

Key: 1

Sol:

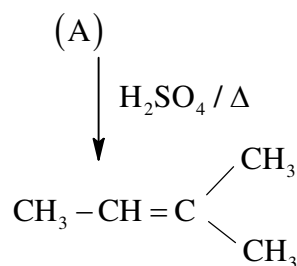
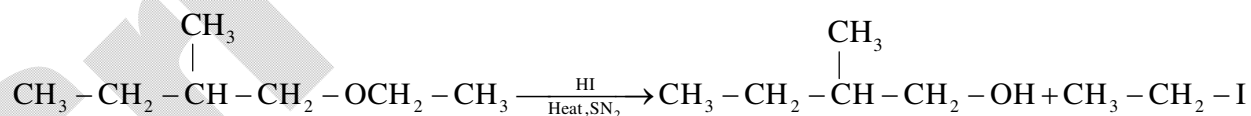

(B)

(NUMERICAL VALUE TYPE)

This section contains 5 questions. Each question is numerical value. For each question, enter the correct numerical value (in decimal notation, truncated/ rounded-off to second decimal place.(e.g. 6.25, 7.00, -0.33, -.30, 30.27, -127.30).

Marking scheme: +4 for correct answer , 0 if not attempted and 0 in all other cases.

21. The osmotic pressure of a solution of NaCl is 0.10 atm and that of a glucose solution is 0.20 atm. The osmotic pressure of a solution formed by mixing 1 L of the sodium chloride solution with 2 L of the glucose solution is $x \times 10^{-3}$ atm. X is _____.
(nearest integer)

Key: 167.00

Sol:

$$\text{Sol: } 0.1 = 2(M_{\text{NaCl}})RT$$

$$0.2 = (M_{\text{glucose}})RT$$

On mixing two solution

$$[M_{\text{NaCl}}]_{\text{Final}} = \frac{1}{3}(M_{\text{NaCl}})$$

$$[M_{\text{glucose}}]_{\text{Final}} = \frac{2}{3}(M_{\text{glucose}})$$

$$\pi_{\text{mixture}} = [i_{\text{NaCl}} [M_{\text{NaCl}}]_{\text{Final}} + [M_{\text{glucose}}]_{\text{Final}}] RT$$

$$= \left(2 \times \frac{1}{3} \times \frac{0.1}{2RT} + \frac{2}{3} \times \frac{0.2}{RT} \right) RT$$

$$= \frac{0.1}{3} + \frac{0.4}{3} = \frac{0.5}{3} \text{ atm}$$

$$\pi_{\text{mixture}} = \frac{0.5}{3} \times 1000 \times 10^{-3}$$

$$= \frac{500}{3} \times 10^{-3}$$

$$= 166.66 \times 10^{-3}$$

$$= 167 \times 10^{-3}$$

$$x = 167.00$$

22. The number of chiral centres present in threonine is _____

Key: 2

Sol:

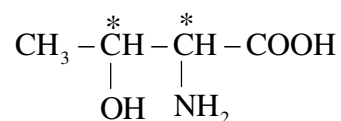

It has 2 chiral centres

23. Consider the following equations :

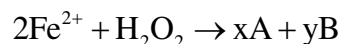

(in basic medium)

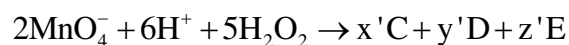

(in acidic medium)

The sum of the stoichiometric coefficients x, y, x', y' and z' for products A, B, C, D and E, respectively, is _____

Key: 19.00

Sol:

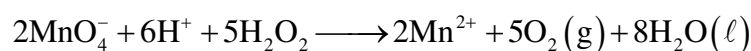
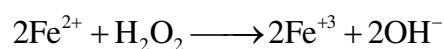

$$x + y = 4$$

$$x' + y' + z' = 15$$

$$x + y + x' + y' + z' = 19$$

24. A 100 mL solution was made by adding 1.43 g of $\text{Na}_2\text{CO}_3 \cdot x\text{H}_2\text{O}$. The normality of the solution is 0.1 N. The value of x is _____.

(The atomic mass of Na is 23 g/mol)

Key: 10.00

Sol:

$$\text{molarity} \times x_F = \text{Normality}$$

$$\text{molarity} = \frac{0.1}{2}$$

$$\text{Moles of } \text{Na}_2\text{CO}_3 \cdot x\text{H}_2\text{O} = \frac{0.1}{2} \times \frac{1}{10}$$

$$\text{Mass of } \text{Na}_2\text{CO}_3 \cdot x\text{H}_2\text{O} = \frac{1}{200} \times \text{molar mass}$$

$$\text{Molar mass} = 106 + x(18)$$

$$\frac{106 + 18x}{200} = 1.43$$

$$106 + 18x = 286$$

$$18x = 180$$

$$x = 10$$

25. The number of molecules with energy greater than the hold energy for a reaction increases five fold by a rise of temperature from 27°C to 42°C. Its energy of activation in J/mol is _____. (Take $\ln 5 = 1.6094$; $R = 8.314 \text{ J mol}^{-1}\text{K}^{-1}$)

Key: 84297.48

Sol:

$$\frac{e^{-E_a/RT_2}}{e^{-E_a/RT_1}} = 5$$

$$\ln 5 = \frac{E_a}{R} \left(\frac{T_2 - T_1}{T_1 T_2} \right)$$

$$1.6094 = \frac{E_a}{8.314} \left(\frac{15}{300 \times 315} \right)$$

$$E_a = 1.6094 \times 8.314 \times 20 \times 315$$

$$E_a = 84297.47508$$

MATHEMATICS**(SINGLE CORRECT ANSWER TYPE)**

This section contains 20 multiple choice questions. Each question has 4 options (1), (2), (3) and (4) for its answer, out of which ONLY ONE option can be correct.

Marking scheme: +4 for correct answer, 0 if not attempted and -1 in all other cases.

1. Let a_1, a_2, \dots, a_n be a given A.P. whose common difference is an integer and $S_n = a_1 + a_2 + \dots + a_n$. If $a_1 = 1$, $a_n = 300$ and $15 \leq n \leq 50$, then the ordered pair (S_{n-4}, a_{n-4}) is equal to:
1. (2490, 249) 2. (2480, 249) 3. (2480, 248) 4. (2490, 248)

Key: 4

Sol :

$a_1, a_2, a_3, \dots, a_n$ _____ A.P

$$a_1 = 1 \quad a_n = 1 + (n-1)d = 300$$

$$(n-1)d = 299 = 13 \times 23$$

$$14 \leq n-1 \leq 49 \quad \Rightarrow (n-1) = 23 \text{ \& } d = 13$$

$$\text{i.e. } n = 24 \quad d = 13$$

$$\text{now } S_{n-4} = \frac{n-4}{2} [{}^2C_4 + (n-5)d]$$

$$= \frac{20}{2} [2 + 19 \times 13]$$

$$= 10 (2 + 247)$$

$$= 2490$$

$$a_{n-4} = 1 + (n-5)d$$

$$= 248$$

2. In a game two players A and B take turns in throwing a pair of fair dice starting with player A and total of scores on the two dice, in each throw is noted. A wins the game if he throws a total of 6 before B throws a total of 7 and B wins the game if he throws a total of 7 before A throws a total of six. The game stops as soon as either of the players wins. The probability of A winning the game is:

1. $\frac{31}{61}$

2. $\frac{5}{31}$

3. $\frac{30}{61}$

4. $\frac{5}{6}$

Key: 3

Sol:

$$\text{Problem of getting a total of 6} = \frac{5}{36}$$

$$\text{Problem of getting a total of 7} = \frac{6}{36}$$

$$\text{now } P(A_{\min}) = P(6) + P(6)P(7)P(6) + P(\bar{6})P(\bar{7})P(\bar{6})P(\bar{7})P(6) + \dots$$

$$= \frac{\frac{5}{36}}{1 - \frac{31 \times 30}{(36)^2}} = \frac{30}{61}$$

3. If the system of equations

$$x + y + z = 2$$

$$2x + 4y - z = 6$$

$$3x + 2y + \lambda z = \mu$$

Has infinitely many solutions, then:

1. $\lambda + 2\mu = 14$

2. $2\lambda - \mu = 5$

3. $2\lambda + \mu = 14$

4. $\lambda - 2\mu = -5$

Key: 3

Sol:

$$x + y + z = 2$$

$$2x + 4y - z = 6$$

$$3x + 2y + \lambda z = \mu$$

For infinite solutions

$$D = \begin{vmatrix} 1 & 1 & 1 \\ 2 & 4 & -1 \\ 3 & 2 & \lambda \end{vmatrix} = 0$$

$$1(4\lambda + 2) - (2\lambda + 3) + 1(4 - 12) = 0$$

$$2\lambda - 1 - 8 = 0 \quad \lambda = \frac{9}{2}$$

$$D_1 = 0 = D_2 = D_3$$

$$D_1 = \begin{vmatrix} 1 & 1 & 2 \\ 2 & 4 & 6 \\ 3 & 2 & \mu \end{vmatrix} = 0$$

$$1(4\mu - 12) - (2\mu - 18) + 2(4 - 12) = 0$$

$$4\mu - 12 - 2\mu + 18 - 16 = 0$$

$$2\mu - 10 = 0$$

$$\mu = 5$$

$$\text{now } 2\lambda + \mu = - + 5 = 14$$

4. The integral

$\int_{\pi/6}^{\pi/3} \tan^3 x \cdot \sin^2 3x (2 \sec^2 x \cdot \sin^2 3x + 3 \tan x \cdot \sin 6x) dx$ is equal to :

1. $-\frac{1}{18}$ 2. $-\frac{1}{9}$ 3. $\frac{9}{2}$ 4. $\frac{7}{18}$

Key: 1

Sol:

$$\int_{\pi/6}^{\pi/3} \tan^3 x \sin^2 3x (2 \sec^2 x \sin^2 3x + 3 \tan x \sin 6x) dx$$

$$\int_{\pi/6}^{\pi/3} \left(\frac{4 \tan^3 x \sec^2 x}{2} \sin^4 3x dx + 6 \tan^4 x \sin^3 3x \cos x \right) dx$$

$$= \frac{1}{2} (\tan^4 x \sin^4 3x) \Big|_{\pi/6}^{\pi/3} = -\frac{1}{18}$$

5. Contrapositive of the statement :

'If a function f is differentiable at a , then it is also continuous at a ', is :

1. If a function f is continuous at a , then it is differentiable at a .
2. If a function f is not continuous at a , then it is differentiable at a .
3. If a function f is continuous at a , then it is not differentiable at a .
4. If a function f is not continuous at a , then it is not differentiable at a .

Key: 4

Sol: Con positive of $p \Rightarrow q$ is $\sim q \Rightarrow \sim p$

6. If a and b are real numbers such that $(2 + \alpha)^4 = a + b\alpha$, where $\alpha = \frac{-1 + i\sqrt{3}}{2}$, then $a + b$ is equal to:

1. 33 2. 9 3. 24 4. 57

Key: 2

Sol:

$$(2 + \alpha)^4 = a + b\alpha$$

$$\alpha = -\frac{1}{2} + \frac{i\sqrt{3}}{2} = e^{i\frac{2\pi}{3}} \Rightarrow (2 + \omega)^4 = a + b\omega$$

$$1 + \omega = -\omega^2$$

$$2 + \omega = 1 - \omega^2$$

$$(1 - \omega^2)^4 = a + b\omega$$

$$1 - 4\omega^2 + 6\omega^4 - 4\omega^6 + \omega^8 = a + b\omega$$

$$1 - 4\omega^2 + 6\omega - 4 + \omega^2 = a + b\omega$$

$$6\omega - 3\omega^2 - 3 = a + b\omega$$

$$9\omega - 3(\omega + \omega^2) - 3 = a + b\omega$$

$$9\omega + 3 - 3 = a + b\omega$$

$$a = 0, b = 9$$

$$\text{so } a + b = 9$$

7. The solution of the differential equation $\frac{dy}{dx} - \frac{y+3x}{\log_e(y+3x)} + 3 = 0$ is :

(where C is a constant of integration.)

1. $x - \log_e(y+3x) = C$

2. $x - 2\log_e(y+3x) = C$

3. $x - \frac{1}{2}(\log_e(y+3x))^2 = C$

4. $y + 3x - \frac{1}{2}(\log_e x)^2 = C$

Key: 3

Sol: $\frac{dy}{dx} - \frac{y+3x}{\ln(y+3x)} + 3 = 0$

$$dy + 3dx = \frac{(y+3x)}{\ln(y+3x)} dx$$

$$\frac{\ln(y+3x)}{y+3x} (d(y+3x)) = dx$$

integrate both sides

$$\frac{\ln^2(y+3x)}{2} = x + c$$

$$\text{or } x - \frac{1}{2}\ln^2(y+3x) = C$$

8. The function $f(x) = \begin{cases} \frac{\pi}{4} + \tan^{-1} x, & |x| \leq 1 \\ \frac{1}{2}(|x|-1), & |x| > 1 \end{cases}$ is:

1. both continuous and differentiable on $\mathbb{R} - \{-1\}$
2. both continuous and differentiable on $\mathbb{R} - \{1\}$
3. continuous on $\mathbb{R} - \{1\}$ and differentiable on $\mathbb{R} - \{-1, 1\}$.
4. continuous on $\mathbb{R} - \{-1\}$ and differentiable on $\mathbb{R} - \{-1, 1\}$.

Key: 3

Sol: $f(x) = \begin{cases} \frac{\pi}{4} + \tan^{-1} x & |x| \leq 1 \\ \frac{1}{2}(|x|-1) & |x| > 1 \end{cases}$

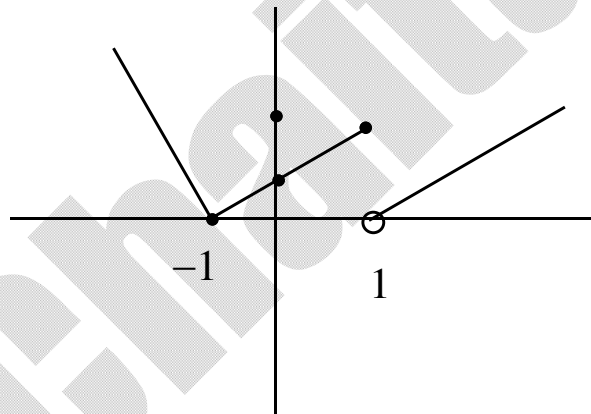

So continuous on $\mathbb{R} - \{1\}$ and differentiable $\mathbb{R} - \{-1, 1\}$

9. The circle passing through the intersection of the circles, $x^2 + y^2 - 6x = 0$ and $x^2 + y^2 - 4y = 0$, having its centre on the line, $2x - 3y + 12 = 0$, also passes through the point:
1. (1, -3)
 2. (-3, 6)
 3. (-3, 1)
 4. (-1, 3)

Key: 2

Sol: $x^2 + y^2 - 6x = 0$

$$x^2 + y^2 - 4y = 0$$

A through their point of integer

$$x^2 + y^2 - 6x + \lambda(x^2 + y^2 - 4y) = 0$$

Its centre $\left(\frac{3}{1+\lambda}, \frac{2\lambda}{1+\lambda}\right)$

It lie on $2x - 3y + 12 = 0 \Rightarrow \frac{6}{1+\lambda} - \frac{6\lambda}{1+\lambda} + 12 = 0$

$$6 - 6\lambda + 12 + 12\lambda = 0 \quad 6\lambda = -18$$

$$\lambda = -3$$

$$x^2 + y^2 - 6x - 3(x^2 + y^2 - 4y) = 0$$

$$-2x^2 - 2y^2 - 6x + 12y = 0$$

$$x^2 + y^2 + 3x - 6y = 0$$

It passes through $(-3, 6)$

10. The minimum value of $2^{\sin x} + 2^{\cos x}$ is :

1. $2^{1-\sqrt{2}}$

2. $2^{-1+\sqrt{2}}$

3. $2^{-1+\frac{1}{\sqrt{2}}}$

4. $2^{1-\frac{1}{\sqrt{2}}}$

Key: 4

Sol:

$$2^{\sin x} + 2^{\cos x}$$

use A.M \geq G.M

$$\frac{2^{\sin x} + 2^{\cos x}}{2} \geq \sqrt{2^{\sin x + \cos x}}$$

$$2^{\sin x} + 2^{\cos x} \geq 2 \cdot 2^{\frac{\sin x + \cos x}{2}}$$

$$\geq 2 \cdot 2^{\frac{1}{\sqrt{2}}}$$

11. Let $f : (0, \infty) \rightarrow (0, \infty)$ be a differentiable function such that $f(1) = e$ and

$$\lim_{t \rightarrow x} \frac{t^2 f^2(x) - x^2 f^2(t)}{t - x} = 0$$

If $f(x) = 1$, then x is equal to:

1. $\frac{1}{e}$

2. e

3. 2e

4. $\frac{1}{2e}$

Key: 1

Sol:

$$f : (0, \infty) \rightarrow (0, \infty) \quad f(1) = e$$

$$\lim_{t \rightarrow x} \frac{t^2 f^2(x) - x^2 f^2(t)}{t - x}$$

Using L' hospital's rule

$$\lim_{t \rightarrow x} \frac{2tf^2(x) - x^2 \cdot 2f(t)f'(t)}{1}$$

$$= 2xf^2(x) - x^2 2f(x)f'(x) = 0$$

$$\Rightarrow 2xf(x) = 2x^2 f'(x)$$

$$\frac{f'(x)}{f(x)} = \frac{1}{x}$$

Integrate $\ln f(x) = \ln x + C$

$$f(1) = e \Rightarrow C = 1$$

$$\ln f(x) = \ln x + 1$$

$$f(x) = ex$$

$$\text{If } f(x) = 1 = ex \quad \Rightarrow x = \frac{1}{e}$$

12. The angle of elevation of a cloud C from a point P, 200 m above a still lake is 30° . If the angle of depression of the image of C in the lake from the point P is 60° , then PC (in m) is equal to :

1. 100 2. 400 3. $200\sqrt{3}$ 4. $400\sqrt{3}$

Key: 2

Sol:

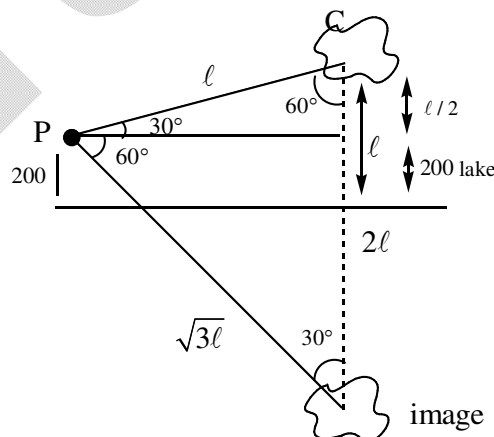

$$\Rightarrow l = \frac{l}{2} + 200$$

$$\Rightarrow l = 400$$

$$\text{So} \quad \text{PC} = l = 400$$

13. Let $x = 4$ be a directrix to an ellipse whose centre is at the origin and its eccentricity is $\frac{1}{2}$.
If $P(1, \beta), \beta > 0$ is a point on this ellipse, then the equation of the normal to it at P is:
1. $8x - 2y = 5$ 2. $4x - 2y = 1$ 3. $4x - 3y = 2$ 4. $7x - 4y = 1$

Key: 2

Sol:

$$e = \frac{1}{2} \qquad \frac{a}{e} = 4 \qquad a = 2$$

$$\text{Ellipse } \frac{x^2}{a^2} + \frac{y^2}{b^2} = 1 \quad b^2 = a^2(1 - e^2) = 4 \times \frac{3}{4} = 3$$

$$\text{so ellipse } \frac{x^2}{4} + \frac{y^2}{3} = 1 \qquad x = 1 \quad y = \frac{3}{2} \Rightarrow \beta = \frac{3}{2}$$

Now equation of normal

$$\frac{a^2x}{1} - \frac{b^2y}{3/2} = a^2e^2 \quad 4x - 2y = 1$$

14. Let $\lambda \neq 0$ be in \mathbb{R} . If α and β are the roots of the equation, $x^2 - x + 2\lambda = 0$ and α and γ are the roots of the equation, $3x^2 - 10x + 27\lambda = 0$, then $\frac{\beta\gamma}{\lambda}$ is equal to:
1. 27 2. 36 3. 18 4. 9

Key: 3

Sol: $\lambda \neq 0$ be in \mathbb{R}

$$x^2 - x + 2\lambda = 0 \begin{cases} \alpha \\ \beta \end{cases}$$

$$3x^2 - 10x + 27\lambda = 0 \begin{cases} \alpha \\ \beta \end{cases}$$

$\alpha =$ common root is also a root of

$$3x^2 - 3x + 6\lambda = 0$$

$$3x^2 - 10x + 27\lambda = 0$$

$$\begin{array}{r} - \quad + \quad - \\ 7x - 21\lambda = 0 \end{array}$$

$$x = 3\lambda = \alpha$$

$$\alpha\beta = 2\lambda \Rightarrow \beta = \frac{2}{3}$$

$$\alpha\gamma = 9\lambda \Rightarrow \gamma = 3$$

Now $\beta\gamma = 2$ also $\alpha = 3\lambda$ satisfies $x^2 - x + 2\lambda = 0$

$$\Rightarrow 9\lambda^2 - 3\lambda + 2\lambda = 0 \quad 9\lambda^2 - \lambda = 0$$

$$\lambda = \frac{1}{9}, \quad \text{So } \frac{\beta\gamma}{\lambda} = \frac{2}{1/9} = 18$$

15. The distance of the point $(1, -2, 3)$ from the plane $x - y + z = 5$ measured parallel to the line $\frac{x}{2} = \frac{y}{3} = \frac{z}{-6}$ is:
1. $\frac{1}{7}$ 2. 7 3. 1 4. $\frac{7}{5}$

Key: 3

Sol:

write PQ \parallel to $\frac{x}{2} = \frac{y}{3} = \frac{z}{-6}$

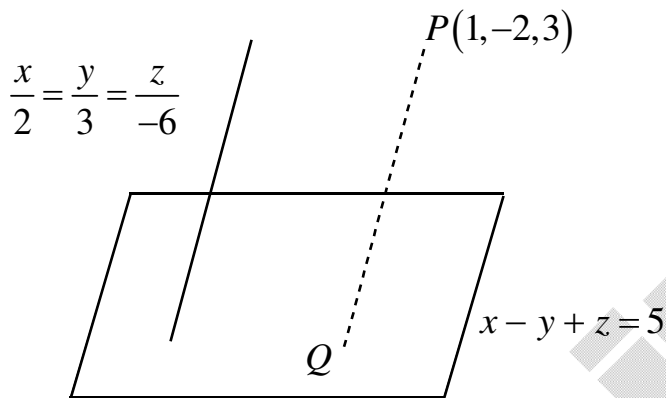

$$\frac{x-1}{2} = \frac{y+2}{3} = \frac{z-3}{-6} = \lambda$$

$$Q(2\lambda+1, 3\lambda-2, -6\lambda+3)$$

Q is on $x - y + z = 5$

$$\Rightarrow 2\lambda + 1 - 3\lambda + 2 - 6\lambda + 3 = 5$$

$$-7\lambda = -1$$

$$\lambda = 1/7$$

$$\Rightarrow Q = \left(\frac{9}{7}, \frac{-11}{7}, \frac{15}{7} \right)$$

$$\text{So } PQ = \sqrt{\left(1 - \frac{9}{7}\right)^2 + \left(-2 + \frac{11}{7}\right)^2 + \left(3 - \frac{15}{7}\right)^2}$$

$$= \sqrt{\frac{4}{49} + \frac{9}{49} + \frac{36}{49}} = 1$$

16. The area (in sq. units) of the largest rectangle ABCD whose vertices A and B lie on the x-axis and vertices C and D lie on the parabola, $y = x^2 - 1$ below the x-axis, is:
1. $\frac{4}{3}$ 2. $\frac{1}{3\sqrt{3}}$ 3. $\frac{4}{3\sqrt{3}}$ 4. $\frac{2}{3\sqrt{3}}$

Key: 3

Sol:

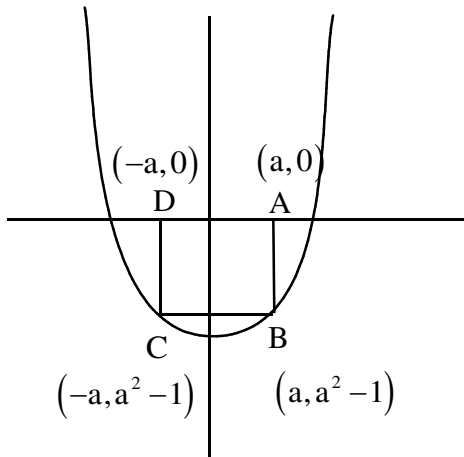

$$\text{Area} = 2a|a^2 - 1|$$

$$A = 2a(1 - a^2)$$

$$\text{for max } \frac{dA}{da} = 2 - 6a^2 = 0$$

$$a = \pm \frac{1}{\sqrt{3}}$$

$$\frac{d^2A}{da^2} = -12a$$

$$\text{For max } a = \frac{1}{\sqrt{3}}$$

$$\text{So ans } \frac{2}{\sqrt{3}} \left(1 - \frac{1}{3}\right)$$

$$\frac{4}{3\sqrt{3}}$$

17. Let $s \bigcup_{i=1}^{50} X_i = \bigcup_{i=1}^n Y_i = T$, where each X_i contains 10 elements and each Y_i contains 5 elements. If each element of the set T is an element of exactly 20 of sets X_i 's and exactly 6 of sets Y_i 's, then n is equal to:

1. 50

2. 45

3. 30

4. 15

Key: 3

Sol:

$$\bigcup_{i=1}^{50} x_i = \bigcup_{i=1}^n y_i = T$$

$$\frac{10 \times 50}{20} = \frac{5n}{6}$$

$$n = 30$$

18. Suppose the vectors x_1, x_2 and x_3 are the solutions of the system of linear equations, $Ax = b$ when the vector b on the right side is equal to b_1, b_2 and b_3 respectively. If

$$x_1 = \begin{bmatrix} 1 \\ 1 \\ 1 \end{bmatrix}, x_2 = \begin{bmatrix} 0 \\ 2 \\ 1 \end{bmatrix}, x_3 = \begin{bmatrix} 0 \\ 0 \\ 1 \end{bmatrix}, b_1 = \begin{bmatrix} 1 \\ 0 \\ 0 \end{bmatrix},$$

$$b_2 = \begin{bmatrix} 0 \\ 2 \\ 0 \end{bmatrix} \text{ and } b_3 = \begin{bmatrix} 0 \\ 0 \\ 2 \end{bmatrix}, \text{ then the determinant of } A \text{ is equal to :}$$

1. 4 2. $\frac{3}{2}$ 3. $\frac{1}{2}$ 4. 2

Key: 4

Sol:

$$Ax = b$$

$$Ax_1 = b_1 \quad Ax_2 = b_2 \quad Ax_3 = b_3$$

$$\text{Let } A = \begin{bmatrix} l_1 & l_2 & l_3 \\ m_1 & m_2 & m_3 \\ n_1 & n_2 & n_3 \end{bmatrix}$$

$$Ax_3 = b_3 \Rightarrow \begin{bmatrix} l_1 & l_2 & l_3 \\ m_1 & m_2 & m_3 \\ n_1 & n_2 & n_3 \end{bmatrix} \begin{bmatrix} 0 \\ 0 \\ 1 \end{bmatrix} = \begin{bmatrix} 0 \\ 0 \\ 2 \end{bmatrix} \Rightarrow \begin{bmatrix} l_3 \\ m_3 \\ n_3 \end{bmatrix} = \begin{bmatrix} 0 \\ 0 \\ 2 \end{bmatrix}$$

$$l_3 = 0, m_3 = 0, n_3 = 2$$

$$Ax_2 = b_2 \Rightarrow \begin{bmatrix} l_1 & l_2 & 0 \\ m_1 & m_2 & 0 \\ n_1 & n_2 & 2 \end{bmatrix} \begin{bmatrix} 0 \\ 2 \\ 1 \end{bmatrix} = \begin{bmatrix} 0 \\ 2 \\ 0 \end{bmatrix}$$

$$\begin{bmatrix} 2l_2 \\ 2m_2 \\ 2n_2 + 2 \end{bmatrix} = \begin{bmatrix} 0 \\ 2 \\ 0 \end{bmatrix} \quad l_2 = 0, m_2 = 1, n_2 = -1$$

$$\text{now } Ax_1 = b_1$$

$$\begin{bmatrix} l_1 & 0 & 0 \\ m_1 & 1 & 0 \\ n_1 & -1 & 2 \end{bmatrix} \begin{bmatrix} 1 \\ 1 \\ 1 \end{bmatrix} = \begin{bmatrix} 1 \\ 0 \\ 0 \end{bmatrix} \quad l_1 = 1, m_1 = -1, n_1 = -1$$

$$|A| = \begin{vmatrix} 1 & 0 & 0 \\ -1 & 1 & 0 \\ -1 & -1 & 2 \end{vmatrix} = 2$$

19. If the perpendicular bisector of the line segment joining the point P(1, 4) and Q(k, 3) has y-intercept equal to -4, then a value of k is :

1. $\sqrt{15}$ 2. $\sqrt{14}$ 3. -4 4. -2

Key: 3

Sol:

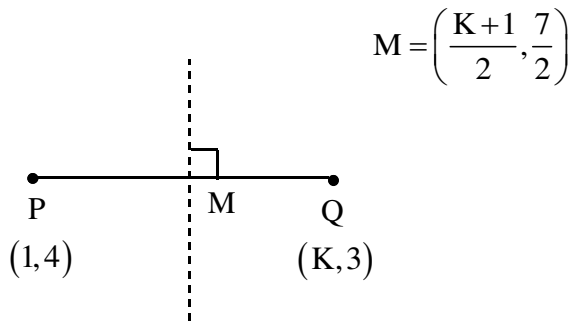

Sol:

Equation of \perp^r bisector

$$y - \frac{7}{2} = \left(\frac{k-1}{1} \right) \left(x - \frac{k+1}{2} \right) \quad y_{\text{int}} = \frac{7}{2} - \frac{(k^2-1)}{2} = -4$$

$$7 - (k^2 - 1) = -8 \quad (k^2 - 1) = 15 \quad k^2 = 16 \quad k = \pm 4$$

20. If for some positive integer n, the coefficients of three consecutive terms in the binomial expansion of $(1+x)^{n+5}$ are in the ratio 5 : 10 : 14, then the largest coefficient in this expansion is:

1. 330 2. 462 3. 792 4. 252

Key: 2

Sol:

$(1+x)^{n+5}$ take 3 consecutive terms as

$$T_r, T_{r+1}, T_{r+2} \quad \frac{T_{r+1}}{T_r} = \frac{10}{5} = 2 \quad \frac{T_{r+2}}{T_{r+1}} = \frac{14}{10} = \frac{7}{5}$$

$$\frac{{}^{n+5}C_r}{{}^{n+5}C_{r-1}} = 2 \quad \& \quad \frac{{}^{n+5}C_{r+1}}{{}^{n+5}C_r} = \frac{7}{5} \quad \Rightarrow n - r + 6 = 2r \quad \& \quad 5n - 12r + 18 = 0$$

$$n - 3r + 6 = 0 \quad 5n - 12r - 18 = 0$$

Solve $r = 4 \quad n = 6$

Largest coefficient of ${}^{n+5}C_r = {}^n C_r$

$${}^{11}C_r \quad \max \quad r = 5 \text{ or } 6$$

$$\text{So } {}^{11}C_5 = {}^{11}C_6 = 462$$

(NUMERICAL VALUE TYPE)

This section contains 5 questions. Each question is numerical value. For each question, enter the correct numerical value (in decimal notation, truncated/rounded-off to second decimal place, (e.g. 6.25, 7.00, -0.33, -.30, 30.27, -127.30).

Marking scheme: +4 for correct answer, 0 if not attempted and 0 in all other cases.

21. Let PQ be a diameter of the circle $x^2 + y^2 = 9$. If α and β are the lengths of the perpendiculars from P and Q on the straight line, $x + y = 2$ respectively, then the maximum value of $\alpha\beta$ is _____

Key: 7

Sol:

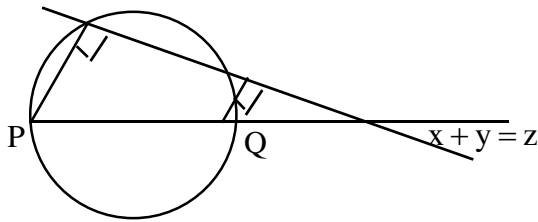

$$P(3\cos\theta, 3\sin\theta)$$

$$Q(-3\cos\theta, -3\sin\theta)$$

$$\alpha = \left| \frac{3\cos\theta + 3\sin\theta - 2}{\sqrt{2}} \right|$$

$$\beta = \left| \frac{-3\cos\theta - 3\sin\theta - 2}{\sqrt{2}} \right|$$

$$\alpha\beta = \left| \frac{4 - 9(1 + \sin 2\theta)}{2} \right|$$

$$= \left| \frac{-5 - 9\sin 2\theta}{2} \right|$$

$$(\alpha\beta)_{\max} = \left| \frac{-5 - 9}{1} \right| = 7$$

22. If $\vec{a} = 2\hat{i} + \hat{j} + 2\hat{k}$, then the value of $|\hat{i} \times (\vec{a} \times \hat{i})|^2 + |\hat{j} \times (\vec{a} \times \hat{j})|^2 + |\hat{k} \times (\vec{a} \times \hat{k})|^2$ is equal to _____

Key: 18

Sol:

$$\vec{a} = 2\hat{i} + \hat{j} + 2\hat{k}$$

$$|\hat{i} \times (\vec{a} \times \hat{i})|^2 + |\hat{j} \times (\vec{a} \times \hat{j})|^2 + |\hat{k} \times (\vec{a} \times \hat{k})|^2$$

$$= 2a^{-2} = 2 \times 9 = 18$$

23. Let $\{x\}$ and $[x]$ denote the fractional part of x and the greatest integer $\leq x$ respectively of a real number x . If $\int_0^n \{x\} dx$, $\int_0^n [x] dx$ and $10(n^2 - n)$, ($n \in \mathbb{N}, n > 1$) are three consecutive terms of a G.P., then n is equal to _____

Key: 21

Sol:

$$\left(\int_0^x [x] dx \right)^2 = \left(\int_0^x \{x\} dx \right)^2 10(x^2 - x) = n \left(\int_0^1 x dx \right)^2 10x(x-1)$$

$$\left(\int_0^x [x] dx - \int_0^x \{x\} dx \right)^2 = n \frac{1}{2} 10x(x-1) \left(\frac{n^2}{2} - \frac{n}{2} \right)^2 = 5n^2(n-1)$$

$$\frac{n^2(n-1)^2}{4} = 5n^2(n-1) \quad n-1=20 \quad n=21$$

24. If the variance of the following frequency distribution :

Class	:	10-20	20-30	30-40
Frequency	:	2	x	2

In 50, then x is equal to _____

Key: 4

Sol:

Class	10 - 20	20 - 30	30 - 40
Frequency	2	x	2

$$\text{Variance} = 50 = \sum \frac{f(x)^2}{f_i} - (\bar{x})^2$$

\bar{x}_i	15	25	35
f_i	2	x	2

$$\bar{x} = \frac{\sum f_i x_i}{\sum f_i}$$

$$= \frac{30 + 25x + 70}{4 + x} = \frac{100 + 25x}{x + 4}$$

$$\bar{x} = 25 \quad \sigma^2 = 50 = \left(\frac{(225 \cdot 2 + 625x + (35)^2)}{4 + x} - (25)^2 \right)$$

$$50 = \frac{(450 + 625x + 2450)}{4 + x} - (25)^2$$

$$50 = \frac{2900 + 625x}{4 + x} - 625$$

$$(675)(4 + x) = 2900 + 625x \quad 2700 + 675x = 2900 + 625x$$

$$50x = 200 \quad x = 4$$

25. A test consists of 6 multiple choice questions, each having 4 alternative answer of which only one is correct. The number of ways, in which a candidate answers all six questions such that exactly four of the answers are correct, is _____

Key: 135

Sol:

$${}^6C_4 \times 1 \times 3 \times$$

Select any 4 ques

Out of 6

$$= 135$$

Ans= (135)

Prepared by
Sri Chaitanya Faculty