



Sri Chaitanya IIT Academy., India

✦ A.P ✦ T.S ✦ Chandigarh ✦ Karnataka ✦ Tamilnadu ✦ Maharashtra ✦ Delhi ✦ Ranchi

Jee Main 2020(Sep)

05-Sep-2020 (Evening Shift)



Question Paper, Key and Solutions

Corporate Office : Plot # 304, Kaset ty Heights, Sri Ayyappa Societ y, Madhapur, Hyderabad – 500081,

Web : www.srichaitanya.net, Email: webmaster@srichaitanya.net, Our Call Center Timings : 9.30 AM to 6.30 PM (Mon – Sat)

Phone : 040-66151515, 040-66060606

Physics

(SINGLE CORRECT ANSWER TYPE)

This section contains 20 multiple choice questions. Each question has 4 options (1), (2), (3) and (4) for its answer, out of which ONLY ONE option can be correct.

Marking scheme: +4 for correct answer, 0 if not attempted and -1 in all other cases.

1. Ten charges are placed on the circumference of a circle of radius R with constant angular separation between successive charges. Alternate charges 1,3, 5,7,9 have charge $(+q)$ each, while 2,4,6,8,10 have charge $(-q)$ each. The potential V and the electric field E at the centre of the circle are respectively. (Take $V = 0$ at infinity)

$$1) V = \frac{10q}{4\pi\epsilon_0 R}; E = 0$$

$$2) V = 0; E = 0$$

$$3) V = \frac{10q}{4\pi\epsilon_0 R}; E = \frac{10q}{4\pi\epsilon_0 R^2}$$

$$4) V = 0; E = \frac{10q}{4\pi\epsilon_0 R^2}$$

Key: 2

Sol: Potential at point C

$$V_c = \frac{kq}{r} + \frac{k(-q)}{r} + \frac{kq}{r} + \frac{k(-q)}{r} + \dots = 0$$

Electric field at C

$$\vec{E}_c = (\vec{E} \text{ due to } +qs) + (\vec{E} \text{ due to } -qs) = 0+0 \text{ from symmetry}$$

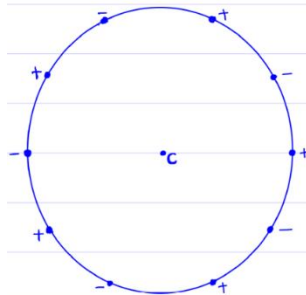

2. In the circuit, given in the figure currents in different branches and value of one resistor are shown. Then potential at point B with respect to the point A is :

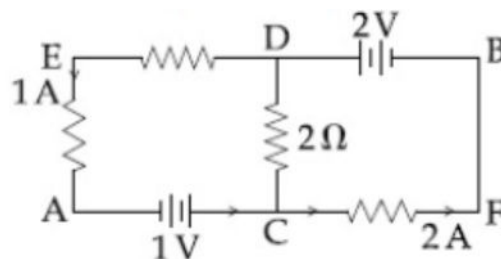

$$1) + 2V$$

$$2) - 2V$$

$$3) + 1V$$

$$4) - 1V$$

Key: 3

Sol: applying KJR at D

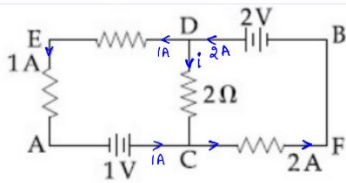

$$2 - 1 - i = 0 \Rightarrow i = 1A, \quad \text{Now } V_B - V_A = 1 + 2(1) - 2 = +1 \text{ volt}$$

3. A radioactive nucleus decays by two different processes. The half life for the first process is 10 s and that for the second is 100 s. The effective half life of the nucleus is close to :

- 1) 12 sec 2) 9 sec 3) 55 sec 4) 6 sec

Key: 2

Sol: If a radioactive sample undergoes two processes simultaneously then

$$\frac{dN}{dt} = -\lambda_1 N - \lambda_2 N = -(\lambda_1 + \lambda_2) N = -\lambda_{\text{eff}} N$$

Given half life of the processes

$$10 = \frac{\ln 2}{\lambda_1}, 100 = \frac{\ln 2}{\lambda_2} \Rightarrow \text{effective process half life} = \frac{\ln 2}{\lambda_{\text{eff}}}$$

$$\frac{\ln 2}{\lambda_{\text{eff}}} = \frac{\ln 2}{\lambda_1 + \lambda_2} = \frac{1}{\frac{1}{10} + \frac{1}{100}} = \frac{100}{11} \approx 9$$

4. A driver in a car, approaching a vertical wall notices that the frequency of his car horn, has changed from 440 Hz to 480 Hz, when it gets reflected from the wall. If the speed of sound in air is 345 m/s, then the speed of the car is:

- 1) 18 km/hr 2) 36 km/hr 3) 54 km/hr 4) 24 km/hr

Key: 3

Sol: frequency of $s^1 = \frac{c}{c-u} f_s$



$$\text{Now frequency observed by driver of the car will be} = \frac{c+u}{c} f_{s^1} = \frac{c+u}{c} \times \frac{c}{c-u} f_s$$

$$\text{As per given data } 480 = \frac{345+u}{345-u} \times 440$$

$$\Rightarrow 12(345-u) = 11(345+u) \Rightarrow 23u = 345 \Rightarrow u = \frac{345}{23} \text{ m/s}$$

$$\Rightarrow y = \frac{345}{23} \times \frac{18}{5} \text{ kmph} = 54 \text{ kmph}$$

5. Two Zener diodes (A and B) having breakdown voltages of 6 V and 4 V respectively, are connected as shown in the circuit below. The output voltage V_o variation with input voltage linearly increasing with time, is given by ($V_{input}=0V$ at $t = 0$) (figures are qualitative)

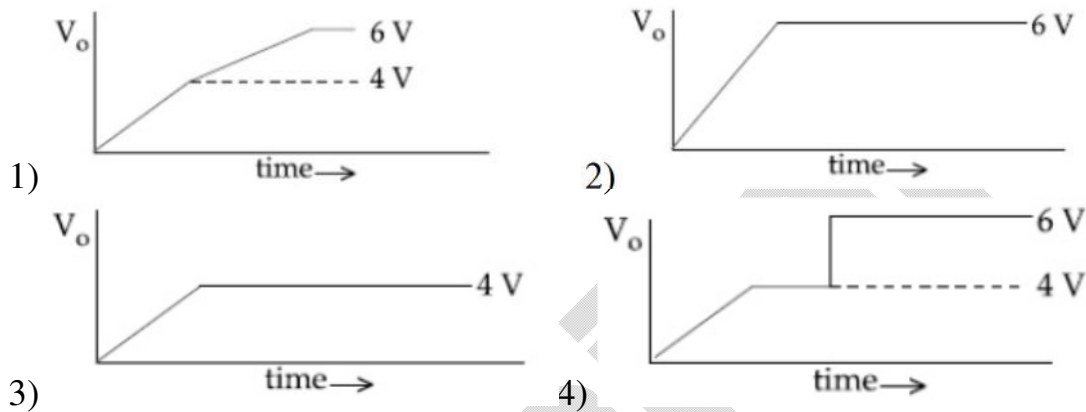
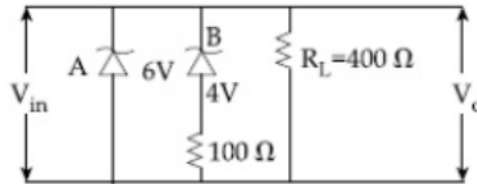

Key: 1

Sol: To get an answer from the options there must be some r as shown

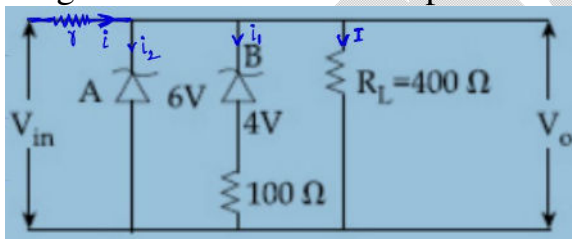

In the beginning $i_2 = 0, i_1 = 0 \Rightarrow i = I = \frac{V_{in}}{r + R_L}$

$$\Rightarrow V_{out} = \frac{V_{in}}{r + R_L} R_L = \left(\frac{KR_L}{r + R_L} \right) t \quad \text{say } V_{in} = kt \Rightarrow V_{out} = m_1 t$$

After V_{out} reaching 4V $\Rightarrow i_1 \neq 0, I < i$

$$V_{in} - ir - IR_L = 0 \Rightarrow V_{in} = IR_L + ir > I(R_L + r) \Rightarrow I < \frac{kt}{R_L + r} \Rightarrow V_{out} = IR_L < \left(\frac{kR_L}{R_L + r} \right) t \Rightarrow V_{out} = m_2 t$$

where $m_2 < m_1$

Now after V_{out} reaches 6 V \Rightarrow diode maintains 6 V const.

6. The correct match between the entries in column I and column II are:

I	II
Radiation	Wavelength
a) Microwave	i) 100 m
b) Gamma rays	ii) 10^{-15} m
c) A.M. radio waves	iii) 10^{-10} m
d) X-rays	iv) 10^{-3} m

1) a-ii,b-i,c-iv,d-iii

2) a-iv,b-ii,c-i,d-iii

3) a-i,b-iii,c-iv,d-ii

4) a-iii,b-ii,c-i,d-iv

Key: 2

Sol: as microwaves $\lambda < 10^{-3} \rightarrow 10^{-1} m$

Gamma Rays $\lambda < 10^{-12} m$

A.m. Radio waves $\lambda > 10^{-1} m$ and x – rays $\lambda : 10^{-12} m \rightarrow 10^{-8} m$

7. A ring is hung on a nail. It can oscillate, without slipping or sliding (i) in its plane with a time period T_1 and, (ii) back and forth in a direction perpendicular to its plane, with a

period T_2 . The ratio $\frac{T_1}{T_2}$ will be

1) $\frac{2}{3}$

2) $\frac{2}{\sqrt{3}}$

3) $\frac{\sqrt{2}}{3}$

4) $\frac{3}{\sqrt{2}}$

Key: 2

Sol:

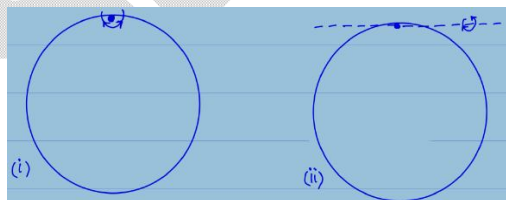

As time period of physical pendulum $T = 2\pi \sqrt{\frac{I}{mgl_c}}$

$$\text{Thus } T_1 = 2\pi \sqrt{\frac{mR^2 + mR^2}{mgR}} = 2\pi \sqrt{\frac{2R}{g}}, T_2 = 2\pi \sqrt{\frac{\frac{mR^2}{2} + mR^2}{mgR}} = 2\pi \sqrt{\frac{3R}{2g}} \Rightarrow \frac{T_1}{T_2} = \frac{2}{\sqrt{3}}$$

8. The velocity (v) and time (t) graph of a body in a straight line motion is shown in the figure. The point S is at 4.333 seconds. The total distance covered by the body in 6 s is :

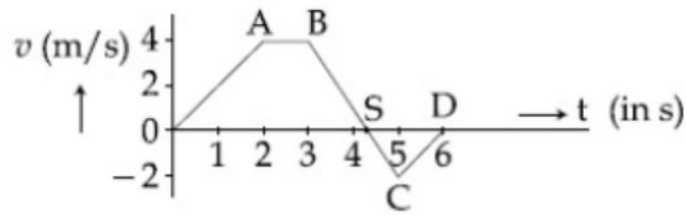

- 1) $\frac{37}{3}$ m 2) 11 m 3) $\frac{49}{4}$ m 4) 12 m

Key: 1

Sol: total distance traversed $s = \int |v| dt =$ sum of magnitude of area under $V - t$ graph

$$S = |\text{area of OABSO}| + |\text{area of SCDS}|$$

$$= \frac{1}{2} \times 4 \times \left(\frac{13}{3} + 1 \right) + \frac{1}{2} \times \left(6 - \frac{13}{3} \right) \times (2) = 2 \times \frac{16}{3} + \frac{5}{3} = \frac{37}{3} \text{ m}$$

9. In an adiabatic process, the density of a diatomic gas becomes 32 times its initial value. The final pressure of the gas is found to be n times the initial pressure. The value of n is :

- 1) 32 2) $\frac{1}{32}$ 3) 326 4) 128

Key: 4

Sol: If density of certain amount of gas becoming 32 times $\Rightarrow V_2 = V_1 / 32$ and it is given that diatomic gas undergoes adiabatic process

$$\Rightarrow P_2 V_2^\gamma = P_1 V_1^\gamma \Rightarrow (n P_1) \left(\frac{V_1}{32} \right)^\gamma = P_1 V_1^\gamma$$

$$\Rightarrow n = 32^\gamma = (32)^{7/5} = 2^7 = 128$$

10. The acceleration due to gravity on the earth's surface at the poles is g and angular velocity of the earth about the axis passing through the pole is ω . An object is weighed at the equator and at a height h above the poles by using a spring balance. If the weights are found to be same, then h is : ($h \ll R$, where R is the radius of the earth)

- 1) $\frac{R^2 \omega^2}{8g}$ 2) $\frac{R^2 \omega^2}{g}$ 3) $\frac{R^2 \omega^2}{4g}$ 4) $\frac{R^2 \omega^2}{2g}$

Key: 4

Sol: Weight of the object near the equator = $m(g - R\omega^2)$ And at height h near the poles = $mg \frac{R^2}{(R+h)^2}$ Given $m(g - R\omega^2) = \frac{mgR^2}{(R+h)^2} = mg \left(1 - \frac{2h}{R}\right)$, $\because h \ll R$

$$R\omega^2 = \frac{2gh}{R} \Rightarrow h = \frac{R^2\omega^2}{2g}$$

11. Two coherent sources of sound, S_1 and S_2 , produce sound waves of the same wavelength, $\lambda = 1$ m, in phase. S_1 and S_2 are placed 1.5 m apart (see fig). A listener, located at L, directly in front of S_2 finds that the intensity is at a minimum when he is 2 m away from S_2 . The listener moves away from S_1 , keeping his distance from S_2 fixed. The adjacent maximum of intensity is observed when the listener is at a distance d from S_1 . Then, d is :

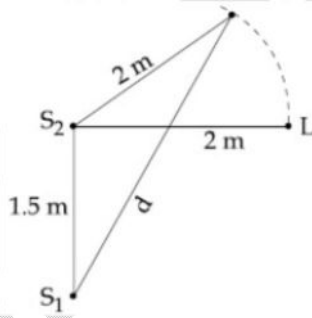

1) 5 m

2) 3 m

3) 12 m

4) 2 m

Key: 2

Sol: at L: $\Delta\phi = \frac{2\pi}{\lambda} \left(\sqrt{4 + \frac{9}{4}} - 2 \right) = 2\pi \left(\frac{5}{2} - 2 \right) = \pi$: minimaNow at other position $\Delta\phi = \frac{2\pi}{\lambda} (d - 2) = 2\pi$, (\because more π , nearby maxima condition)

$$\Rightarrow d = 3\text{m}$$

12. A spaceship in space sweeps stationary interplanetary dust. As a result, its mass increases at a rate $\frac{dM(t)}{dt} = bv^2(t)$, where $v(t)$ is its instantaneous velocity. The instantaneous acceleration of the satellite is:

1) $-\frac{2bv^3}{M(t)}$

2) $-bv^3(t)$

3) $-\frac{bv^3}{2M(t)}$

4) $-\frac{bv^3}{M(t)}$

Key: 4

Sol: as $m \frac{dv}{dt} = -\dot{u} \frac{dm}{dt} + O \Rightarrow m \frac{dv}{dt} = (-v)(bv^2) \Rightarrow \frac{dv}{dt} = -\frac{bv^3}{m(t)}$

13. In the circuit shown, charge on the $5 \mu\text{F}$ capacitor is :

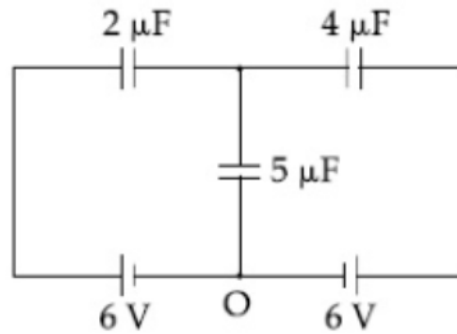

- 1) $16.36 \mu\text{C}$ 2) $5.45 \mu\text{C}$ 3) $10.90 \mu\text{C}$ 4) $18.00 \mu\text{C}$

Key: 1

Sol: applying KJR $q = q_1 + q_2$

Applying LKR $6 - \frac{q_1}{2} - \frac{q}{5} = 0$

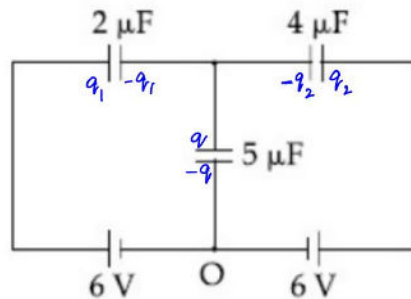

And $6 - \frac{q_2}{4} - \frac{q}{5} = 0$

$\Rightarrow q_2 = 2q_1 \Rightarrow q = 3q_1 \Rightarrow 6 - \frac{q}{6} - \frac{q}{5} = 0 \Rightarrow \frac{11}{30}q = 6 \Rightarrow q = \frac{180}{11} \mu\text{C} = 16.36 \mu\text{C}$

14. The quantities $x = \frac{1}{\sqrt{\mu_0 \epsilon_0}}$, $y = \frac{E}{B}$ and $z = \frac{l}{CR}$ are defined where C-capacitance, R-

Resistance, l -length, E-Electric field, B-magnetic field and ϵ_0, μ_0 - free space permittivity and permeability respectively. Then :

- 1) Only x and z have the same dimension
- 2) Only x and y have the same dimension
- 3) Only y and z have the same dimension
- 4) x, y and z have the same dimension

Key: 2

Sol: $x = \frac{1}{\sqrt{\mu_0 \epsilon_0}} \Rightarrow$ dimensional formula of $x = [m^{\circ} L T^{-1}]$ $y = \frac{E}{B} \Rightarrow [y] = [m^{\circ} L T^{-1}]$, $[z] = [m^{\circ} L^{\circ} T^{-1}]$

15. A galvanometer is used in laboratory for detecting the null point in electrical experiments. If, on passing a current of 6 mA it produces a deflection of 2° , its figure of merit is close to :

- 1) 333° A/div 2) 3×10^{-3} A/div 3) 6×10^{-3} A/div 4) 666° A/div

Key: 2

Sol: Figure of merit of a galvanometer = reciprocal of current sensitivity

$$= \frac{6mA}{2^{\circ}} = 3 \times 10^{-3} \text{ A / degree}$$

16. A parallel plate capacitor has plate of length 'l', width 'w' and separation of plates is 'd'. It is connected to a battery of emf V. A dielectric slab of the same thickness 'd' and of dielectric constant $k = 4$ is being inserted between the plates of the capacitor. At what length of the slab inside plates, will the energy stored in the capacitor be two times the initial energy stored?

- 1) $l/4$ 2) $l/2$ 3) $2l/3$ 4) $l/3$

Key: 4

Sol:



Energy stored in capacitor (i) $V_1 = \frac{1}{2} C_1 V^2 = \frac{1}{2} \frac{\epsilon_0 l w}{d} V^2$

Similarly in (ii), $U_2 = \frac{1}{2} C_2 V^2 = \frac{1}{2} \left(\frac{\epsilon_0 (l-x)}{d} + \frac{4\epsilon_0 x w}{d} \right) V^2$

& also given $U_2 = 2U_1 \Rightarrow (l-x) + 4x = 2l \Rightarrow x = l/3$

17. In an experiment to verify Stokes law, a small spherical ball of radius r and density ρ falls under gravity through a distance h in air before entering a tank of water. If the terminal velocity of the ball inside water is same as its velocity just before entering the water surface, then the value of h is proportional to : (ignore viscosity of air)

- 1) r^4 2) r^2 3) r^3 4) r

Key: 1

Sol: Velocity of the ball after free fall : $V = \sqrt{2gh}$
given it is equal to terminal velocity in a liquid

$$\rho \frac{4}{3} \pi r^3 g - \pi \frac{4}{3} \pi r^3 g = 6\pi\eta rV$$

$$\Rightarrow (\rho - J) \frac{4}{3} \pi r^2 g = 6\pi\eta \sqrt{2gh} \Rightarrow h \propto r^4$$

18. An infinitely long straight wire carrying current I , one side opened rectangular loop and a conductor C with a sliding connector are located in the same plane, as shown in the figure. The connector has length l and resistance R . It slides to the right with a velocity v . The resistance of the conductor and the self inductance of the loop are negligible. The induced current in the loop, as a function of separation r , between the connector and the straight wire is :

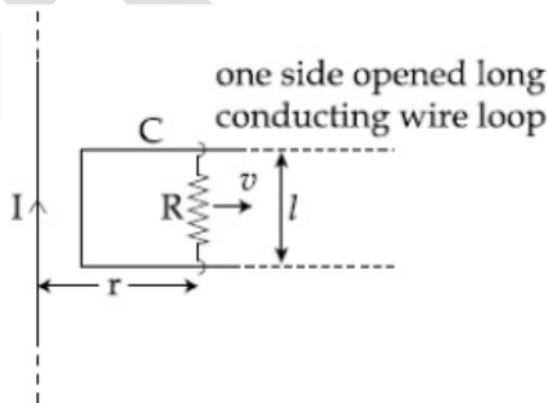

- 1) $\frac{\mu_0 Ivl}{2\pi Rr}$ 2) $\frac{2\mu_0 Ivl}{\pi Rr}$ 3) $\frac{\mu_0 Ivl}{4\pi Rr}$ 4) $\frac{\mu_0 Ivl}{\pi Rr}$

Key: 1

Sol: induced emf = $Blv = \frac{\mu_0 I}{2\pi r} Iv \Rightarrow$ induced current = $\frac{\mu_0 Ivl}{2\pi Rr}$

19. An iron rod of volume 10^{-3}m^3 and relative permeability 1000 is placed as core in a solenoid with 10 turns/cm. If a current of 0.5 A is passed through the solenoid, then the magnetic moment of the rod will be:

- 1) $5 \times 10^2 \text{ Am}^2$ 2) $500 \times 10^2 \text{ Am}^2$ 3) $0.5 \times 10^2 \text{ Am}^2$ 4) $50 \times 10^2 \text{ Am}^2$

Key: 1

Sol: as $B = \mu H = \mu_0 (H + I) \Rightarrow 100\mu_0 ni = \mu_0 (ni + I)$, I : intensity of magnetization

$$\Rightarrow I = 999ni = 999 \times 1000 \times 0.5$$

$$\Rightarrow \text{magnetic moment of the rod} = I \times \text{vol} = 999 \times 500 \times 10^{-3} = \frac{999}{2} = 499.5 \approx 5 \times 10^2 \text{ Am}^2$$

20. Two different wires having length L_1 and L_2 and respective temperature coefficient of linear expansion α_1 and α_2 , are joined end-to-end. Then the effective temperature coefficient of linear expansion is:

- 1) $\frac{\alpha_1 + \alpha_2}{2}$ 2) $2\sqrt{\alpha_1\alpha_2}$ 3) $4 \frac{\alpha_1\alpha_2}{\alpha_1 + \alpha_2} \frac{L_2L_1}{(L_2 + L_1)^2}$ 4) $\frac{\alpha_1L_1 + \alpha_2L_2}{L_1 + L_2}$

Key: 4

Sol: Thermal expansion on small size in temp.

$$L_{\text{eff}} \alpha_{\text{eff}} d\theta = L_1 \alpha_1 d\theta + L_2 \alpha_2 d\theta$$

$$\alpha_{\text{eff}} = \frac{L_1 \alpha_1 + L_2 \alpha_2}{L_1 + L_2}$$

(NUMERICAL VALUE TYPE)

This section contains 5 questions. Each question is numerical value. For each question, enter the correct numerical value (in decimal notation, truncated/rounded-off to second decimal place. (e.g. 6.25, 7.00, -0.33, -30, 30.27, -127.30).

Marking scheme: +4 for correct answer, 0 if not attempted and 0 in all other cases.

21. A thin rod of mass 0.9 kg and length 1 m is suspended, at rest, from one end so that it can freely oscillate in the vertical plane. A particle of mass 0.1 kg moving in a straight line with velocity 80 m/s hits the rod at its bottom most point and sticks to it (see figure). The angular speed (in rad/s) of the rod immediately after the collision will be _____

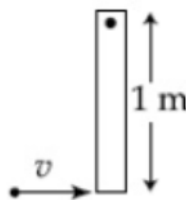

Key: 20.00

Sol:

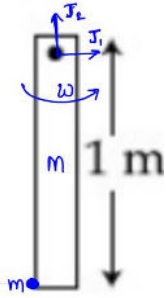

Let J_1 and J_2 are the impulses by the hinge
applying conservation of angular momentum of particle + rod about the hinge

$$1 \times 0.1 \times 80 + 0 = \left(0.1 \times 1^2 + \frac{0.9 \times 1^2}{3} \right) \omega$$

$$\Rightarrow 8 = 0.4\omega \Rightarrow \omega = 20 \text{ rad/s}$$

22. Nitrogen gas is at 300°C temperature. The temperature (in K) at which the rms speed of a H_2 molecule would be equal to the rms speed of a nitrogen molecule, is ____.
(Molar mass of N_2 gas 28 g).

Key: 40.93

Sol: Let T is the temperature of H_2 gas

$$\text{Given } \sqrt{\frac{3RT}{M_{\text{H}_2}}} = \sqrt{\frac{3R(273+300)}{M_{\text{N}_2}}} \Rightarrow T = \frac{573}{28} \times 2 = \frac{573}{14} = 40.93$$

23. A body of mass 2kg is driven by an engine delivering a constant power of 1 J/s. The body starts from rest and moves in a straight line. After 9 seconds, the body has moved a distance (in m) ____.

Key: 18

Sol: given const power $\Rightarrow pt = \frac{1}{2}mv^2 - \frac{1}{2}mu^2 = \frac{1}{2}mv^2, (\because u = 0)$

$$\Rightarrow 1 \times t = \frac{1}{2} \times 2 \times v^2 \Rightarrow v = \sqrt{t}$$

$$\Rightarrow \text{dist. travelled } s = \int_0^9 \sqrt{t} dt = \left[\frac{2}{3}(t)^{3/2} \right]_0^9 = \frac{2}{3} \left[(9)^{3/2} - 0 \right] = \frac{2}{3} \times 27 = 18 \text{ m}$$

24. A prism of angle $A = 1^\circ$ has a refractive index $\mu = 1.5$. A good estimate for the minimum angle of deviation (in degrees) is close to $N/10$. Value of N is _____.

Key: 5

Sol: deviation for small angled prism $\delta = (\mu - 1)A$

$$\Rightarrow (1.5 - 1)1 = 0.5^\circ = \frac{5}{10} \Rightarrow N = 5$$

25. The surface of a metal is illuminated alternately with photons of energies $E_1 = 4 \text{ eV}$ and $E_2 = 2.5 \text{ eV}$ respectively. The ratio of maximum speeds of the photoelectrons emitted in the two cases is 2. The work function of the metal in (eV) is _____.

Key: 2

Sol: in (i) $\frac{1}{2}mv_1^2 = 4 - \phi$, in (ii) $\frac{1}{2}mv_2^2 = 2.5 - \phi$ and $v_1 : v_2 = 2 : 1$

$$\Rightarrow \sqrt{\frac{4 - \phi}{2.5 - \phi}} = 2 \Rightarrow 4 - \phi = 10 - 4\phi \Rightarrow \phi = 2 \text{ eV}$$

CHEMISTRY**(SINGLE CORRECT ANSWER TYPE)**

This section contains 20 multiple choice questions. Each question has 4 options (1), (2), (3) and (4) for its answer, out of which ONLY ONE option can be correct.

Marking scheme: +4 for correct answer, 0 if not attempted and -1 in all other cases.

1. The final major product of the following reaction is :

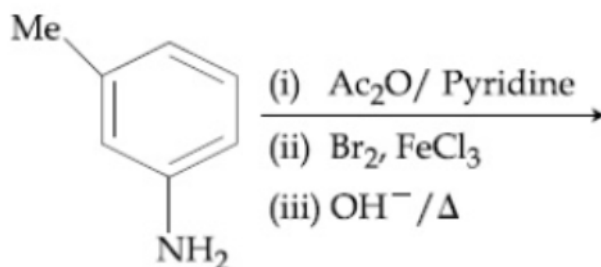

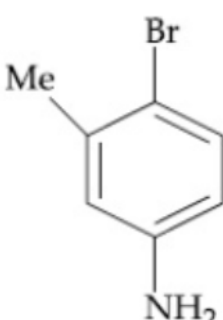
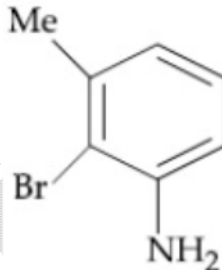
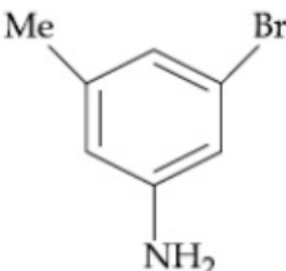
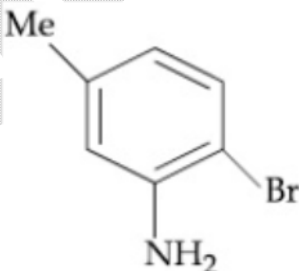
- 1) 
- 2) 
- 3) 
- 4) 

Key: 1

Sol: $-\text{NHCCH}_3$ is moderately activating wins over weak activating $-\text{CH}_3$ and due to bulky nature of $-\text{NHCCH}_3$ attack happens para to $-\text{NHCCH}_3$.

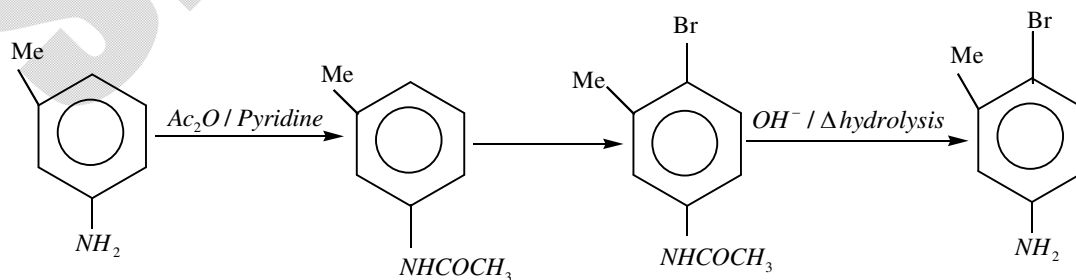

2. The variation of molar conductivity with concentration of an electrolyte (X) in aqueous solution is shown in the given figure.

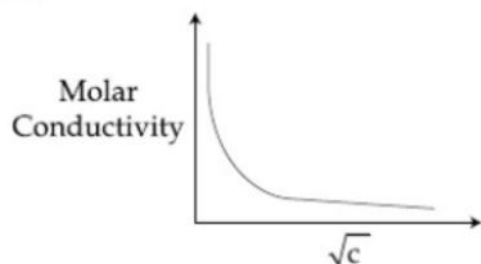

The electrolyte X is:

- 1) HCl 2) CH_3COOH 3) KNO_3 4) NaCl

Key: 2

Sol: For weak electrolytes we get rectangular hyperbola graphs for molar conductivity Vs \sqrt{C} . For strong electrolytes we get straight line. In the given only CH_3COOH is weak electrolyte.

3. The correct statement about probability density (except at infinite distance from nucleus) is :

- 1) It can never be zero for 2s orbital 2) It can be negative for 2p orbital
3) It can be zero for 3p orbital 4) It can be zero for 1s orbital

Key: 3

Sol: a) 2s has one node

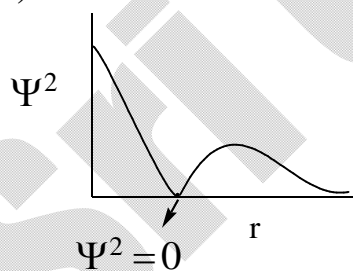

Ψ^2 is zero for 2S¹ orbital

b)

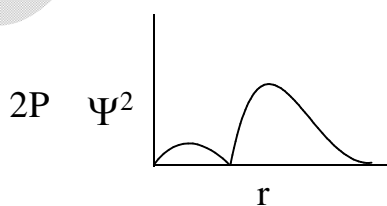

Ψ^2 is not negative

c)

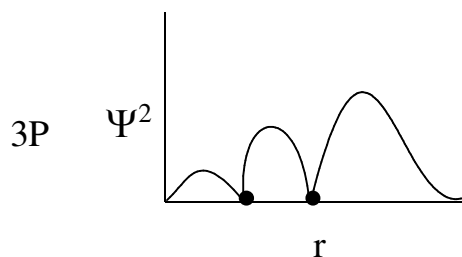

Ψ^2 of 3P is zero at '2' places correct

d)

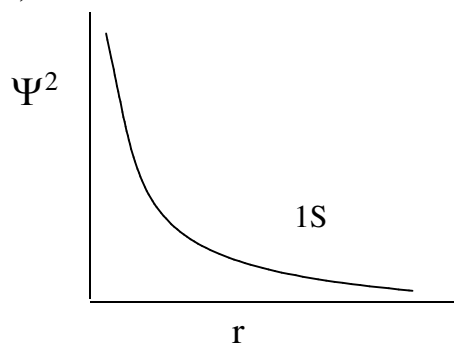

Ψ^2 can't be zero

4. Lattice enthalpy and enthalpy of solution of NaCl are 788 kJ mol^{-1} and 4 kJ mol^{-1} , respectively. The hydration enthalpy of NaCl is :

1) 784 kJ mol^{-1} 2) 780 kJ mol^{-1} 3) -784 kJ mol^{-1} 4) -780 kJ mol^{-1}

Key: 3

Sol: $\Delta H_{\text{solution}} = \Delta H_{\text{lattice}} + \Delta H_{\text{hydration}}$

$$\Delta H_{\text{hydration}} = \Delta H_{\text{solution}} - \Delta H_{\text{lattice}}$$

$$= 4 \text{ kJ} - 788 \text{ kJ}$$

$$= -784 \text{ kJ/mole}$$

5. The one that is NOT suitable for the removal of permanent hardness of water is :

1) Treatment with sodium carbonate 2) Clark's method
3) Ion-exchange method 4) Calgon's method

Key: 2

Sol: Clarke's method of using limited lime water is used to remove temporary hardness of water

6. Among the following compounds, geometrical isomerism is exhibited by:

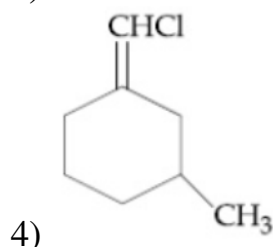
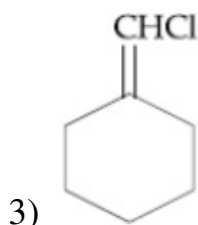
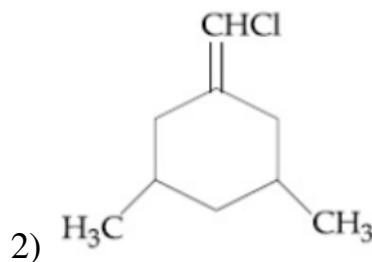
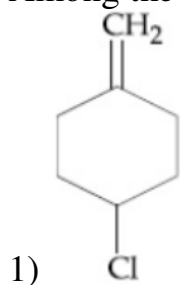

Key: 2

Sol:

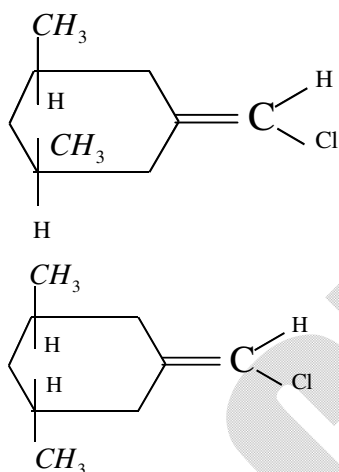

7. The rate constant (k) of a reaction is measured at different temperatures (T), and the data are plotted in the given figure. The activation energy of the reaction in kJ mol^{-1} is : (R is gas constant)

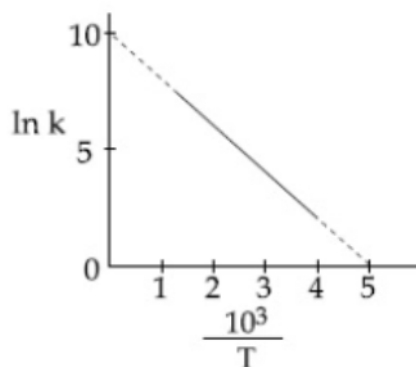

1) $1/R$

2) $2/R$

3) $2R$

4) R

Key: 3

Sol: $\ln K = \ln A - \frac{Ea}{RT}$

$$\rightarrow \frac{10^3}{T} = 0 \quad \text{i.e. } T \rightarrow \infty$$

i.e. $\ln K = \ln A$

at origin $\ln K = 10 = \ln A$

$$\rightarrow \text{at } \frac{10^3}{T} = 5 \Rightarrow T = 200K \quad \ln K = 0$$

$$\ln A = \frac{Ea}{RT}$$

$$10 = \frac{Ea}{R200}$$

$$Ea = 2000 R J \\ = 2R \text{ kJ/mole}$$

8. The major product of the following reaction is:

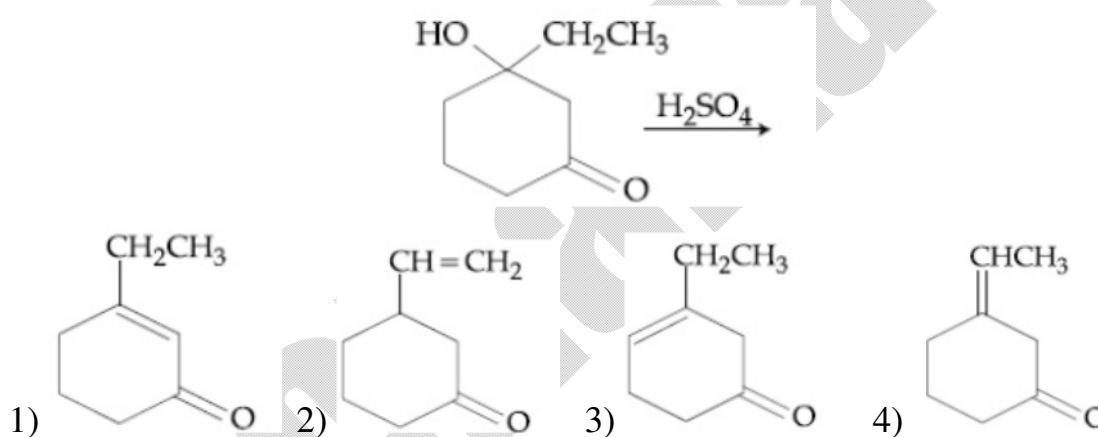

Key: 1

Sol: During elimination, conjugated product is always preferable

9. The increasing order of boiling points of the following compound is:

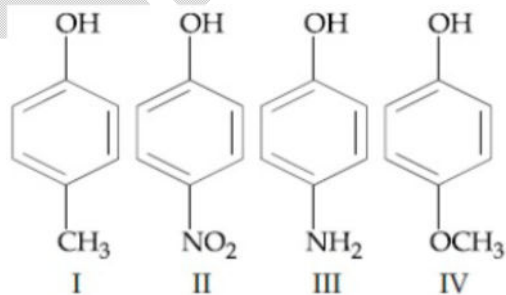

1) III < I < II < IV

2) I < IV < III < II

3) IV < I < II < III

4) I < III < IV < II

Corporate Office : Plot # 304, Kaset ty Heights, Sri Ayyappa Societ y, Madhapur, Hyderabad – 500081,

Web : www.srichaitanya.net, Email: webmaster@srichaitanya.net, Our Call Center Timings : 9.30 AM to 6.30 PM (Mon – Sat)

Phone : 040-66151515, 040-66060606

Key: II (based on dipole moments)

- Sol: I) P-cresol 202°C
 II) P-nitro phenol 279°C
 III) P-aminophenol 284°C
 IV) P-methoxy phenol 243°C

Due to hydrogen bonding B.pt of P-amino phenol is high in other cases greater the 'u', greater is the B.pt III > II > IV > I

10. Which one of the following polymers is not obtained by condensation polymerization?

- 1) Buna -N 2) Nylon 6,6 3) Bakelite 4) Nylon 6

Key: 1

Sol: Nylon means poly amides (condensation polymers)

Bakelite: Ph - OH + HCHO condensation polymer

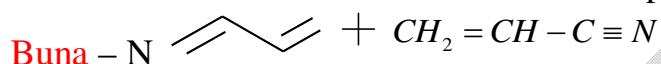

It is an addition polymer

11. The major product formed in the following reaction is:



- 1) $\text{CH}_3\text{CH}_2\text{CH}_2\text{C}(\text{Br})(\text{CH}_3)_2$ 2) $\text{Br}(\text{CH}_2)_3\text{CH}(\text{CH}_3)_2$
 3) $\text{CH}_3\text{CH}(\text{Br})\text{CH}_2\text{CH}(\text{CH}_3)_2$ 4) $\text{CH}_3\text{CH}_2\text{CH}(\text{Br})\text{CH}(\text{CH}_3)_2$

Key: 1

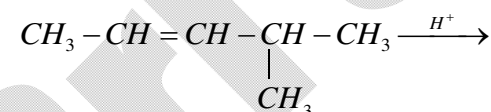

Sol:

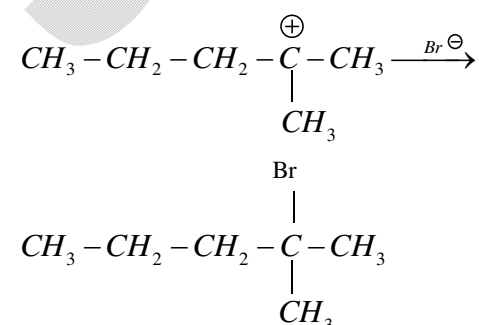

12. Hydrogen peroxide, in the pure state, is:

- 1) linear and almost colorless 2) planar and blue in color
3) linear and blue in color 4) non-planar and almost colorless

Key: 4

Sol: Open book structure is non planar and almost **colorless (pale blue)**

13. Boron and silicon of very high purity can be obtained through:

- 1) vapour phase refining 2) electrolytic refining
3) liquation 4) zone refining

Key: 4

Sol: Zone refining NCERT metallurgy

14. The correct order of the ionic **radii** of

$O^{2-}, N^{3-}, F^{-}, Mg^{2+}, Na^{+}$ and Al^{3+} is:

- 1) $Al^{3+} < Na^{+} < Mg^{2+} < O^{2-} < F^{-} < N^{3-}$ 2) $Al^{3+} < Mg^{2+} < Na^{+} < F^{-} < O^{2-} < N^{3-}$
3) $N^{3-} < O^{2-} < F^{-} < Na^{+} < Mg^{2+} < Al^{3+}$ 4) $N^{3-} < F^{-} < O^{2-} < Mg^{2+} < Na^{+} < Al^{3+}$

Key: 2

Sol: With increasing nuclear charge size decreases in isoelectronic species

15. The following molecule acts as an:

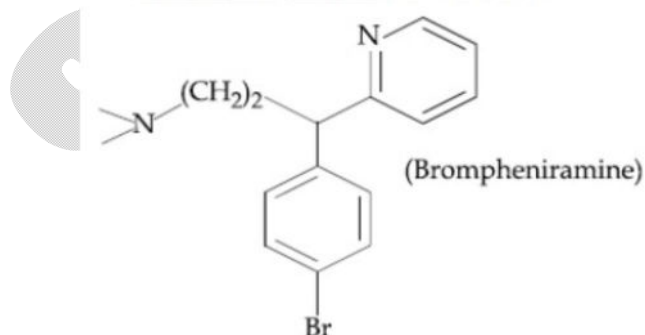

- 1) Anti – depressant 2) **Anti-bacterial**
3) **Anti-histamine** 4) Antiseptic

Key: 3

Sol: NCERT anti histamines

16. An element crystallises in a face-centred cubic (fcc) unit cell with cell edge a . The distance between the centres of two nearest octahedral voids in the crystal lattice is :

- 1) $\frac{a}{\sqrt{2}}$ 2) a 3) $\frac{a}{2}$ 4) $\sqrt{2}a$

Key: 1

Sol: In FCC 'octahedral' voids are at edge centre and body centre

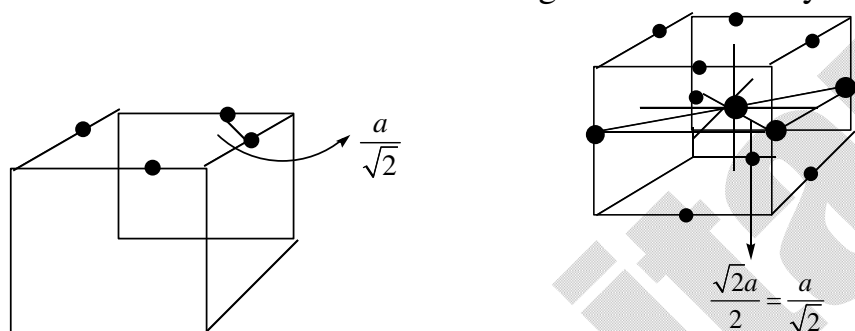

both distances of nearest edge centers (or) edge center and body center are $\frac{a}{\sqrt{2}}$ only

17. Reaction of ammonia with excess Cl_2 gives:

- 1) NH_4Cl and HCl 2) NCl_3 and NH_4Cl
 3) NCl_3 and HCl 4) NH_4Cl and N_2

Key: 3

Sol: $NH_3 + 3Cl_2 \rightarrow NCl_3 + 3HCl$
Excess

18. The compound that has the largest H – M – H bond angle (M = N, O, S, C), is :

- 1) H_2S 2) CH_4 3) H_2O 4) NH_3

Key: 2

Sol:

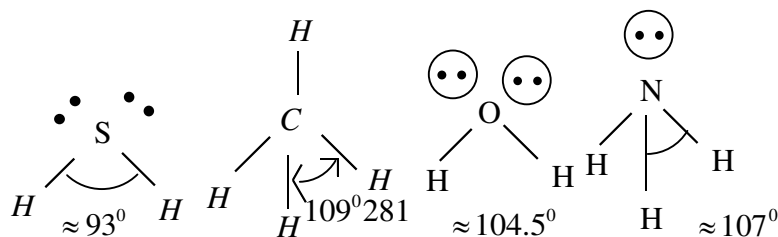

19. Adsorption of a gas follows Freundlich adsorption isotherm. If x is the mass of the gas adsorbed on mass m of the adsorbent, the correct plot of $\frac{x}{m}$ versus p is:

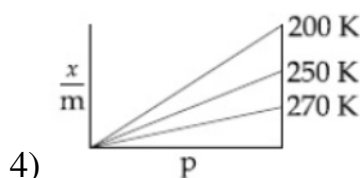
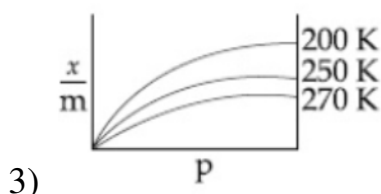
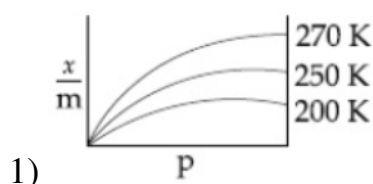

Key: 3

Sol: $\frac{x}{m} = kp^{1/n}$

at high pressures they reach saturation and with increase in temp at a given pressure $\frac{x}{m}$ is less as desorption increases.

20. Consider the complex ions, $trans-[Co(en)_2Cl_2]^+$ (A) and $cis-[Co(en)_2Cl_2]^+$ (B). The correct statement regarding them is:
- 1) (A) can be optically active, but (B) cannot be optically active
 - 2) (A) cannot be optically active, but (B) can be optically active
 - 3) both (A) and (B) can be optically active
 - 4) both (A) and (B) cannot be optically active

Key: 2

Sol:

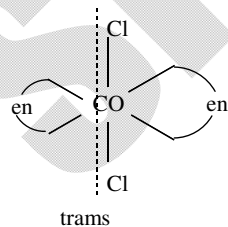

it is optically inactive as it has plane symmetry

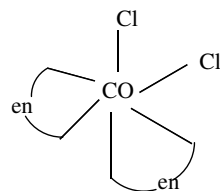

Where as Cis -form has no plane symmetry it is chiral and optically active

(NUMERICAL VALUE TYPE)

This section contains 5 questions. Each question is numerical value. For each question, enter the correct numerical value (in decimal notation, truncated/rounded-off to second decimal place.(e.g. 6.25, 7.00, -0.33, -30, 30.27, -127.30).

Marking scheme: +4 for correct answer, 0 if not attempted and 0 in all other cases.

21. The volume, in mL, of 0.02 M $K_2Cr_2O_7$ solution required to react with 0.288 g of ferrous oxalate in acidic medium is _____.
(Molar mass of Fe = 56 g mol⁻¹)

Key: 50

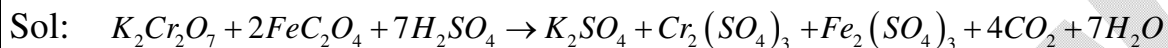

$$\frac{M_1V_1}{n_1}(K_2Cr_2O_7) = \frac{M_2V_2}{n_2}(FeC_2O_4)$$

(Gram molecular weight of FeC_2O_4 , 56+24+64= 144g)

$$\frac{V_1 \times 0.02}{1} = \frac{2}{2} \quad \text{number of moles of } FeC_2O_4 = \frac{0.288}{144} = 2 \text{ millimoles} = MV$$

$$V_1 = \frac{1}{0.02} = 50 \text{ ml}$$

22. For a reaction $X+Y \rightleftharpoons 2Z$, 1.0 mol of X, 1.5 mol of Y and 0.5 mol of Z were taken in a 1 L vessel and allowed to react. At equilibrium, the concentration of Z was 1.0 mol L⁻¹. The equilibrium constant of the reaction is $\frac{x}{15}$. The value of x is _____.

Key: 16

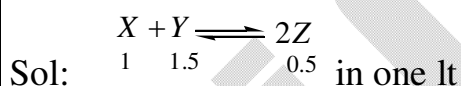

At Eq conc of z = 1 m i.e 1 mole in one lt

Eq shifts forward.

$$1-x \quad 1.5-x \quad 0.5+2x$$

$$0.5 + 2x = 1 \quad x = 0.25$$

$$(X)_{eq} = \frac{3}{4}M \quad (Y)_{eq} = \frac{5}{4}M \quad (Z)_{eq} = 1M \quad Kc = \frac{(1)^2}{\frac{3}{4} \cdot \frac{5}{4}} = \frac{16}{15} = \frac{x}{15}$$

23. The number of chiral carbons present in sucrose is _____.

Key: 9

Sol: Sucrose

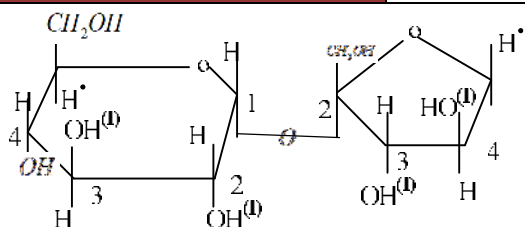

24. Considering that $\Delta_0 > P$, the magnetic moment (in BM) of $[Ru(H_2O)_6]^{2+}$ would be _____.

Key: 0

Sol: 'Ru' is Fe group of 4d series $4d^6 5s^2$ but $Ru^{+2} = 4d^6$
 As $\Delta_0 > P$ electrons prefer to pair up in lower energy t_{2g} of octahedral complex then $t_{2g}^6 e_g^0$ a low spin complex then $n = 0$
 $\mu = \sqrt{n(n+2)} BM : \mu = 0$

25. For a dimerization reaction, $2A(g) \rightarrow A_2(g)$, at 298 K,

$\Delta U^\ominus = -20 kJ mol^{-1}$, $\Delta S^\ominus = -30 J K^{-1} mol^{-1}$, then the ΔG^\ominus will be _____ J.

Key: -13537

Sol: $\Delta H^0 = \Delta U^0 + \Delta nRT$ $\Delta n = -1$
 $\Delta H^0 = -20000 - 1 \times 8.314 \times 298$
 $= -22477 J / mole$
 $\Delta G^0 = \Delta H^0 - T\Delta S^0$
 $\Delta G^0 = -22477 J / mole - 298(-30 J / mole)$
 $= -13537 J$

MATHEMATICS**(SINGLE CORRECT ANSWER TYPE)**

This section contains 20 multiple choice questions. Each question has 4 options (1), (2), (3) and (4) for its answer, out of which ONLY ONE option can be correct.

Marking scheme: +4 for correct answer, 0 if not attempted and -1 in all other cases.

1. The derivative of $\tan^{-1}\left(\frac{\sqrt{1+x^2}-1}{x}\right)$ with respect to $\tan^{-1}\left(\frac{2x\sqrt{1-x^2}}{1-2x^2}\right)$ at $x=\frac{1}{2}$ is:
- 1) $\frac{2\sqrt{3}}{3}$ 2) $\frac{\sqrt{3}}{10}$ 3) $\frac{2\sqrt{3}}{5}$ 4) $\frac{\sqrt{3}}{12}$

Key: 2

Sol: If $x = \tan \theta$

$$\tan^{-1}\left(\frac{\sqrt{1+x^2}-1}{x}\right) = \tan^{-1}\left(\frac{\sec \theta - 1}{\tan \theta}\right)$$

$$= \tan^{-1}\left(\tan \frac{\theta}{2}\right)$$

$$= \frac{1}{2}\theta = \frac{1}{2}\tan^{-1}x$$

If $x = \sin \alpha$,

$$\tan^{-1}\left(\frac{2x\sqrt{1-x^2}}{1-2x^2}\right) = \tan^{-1}\left(\frac{\sin 2\alpha}{\cos 2\alpha}\right)$$

$$= 2\alpha = 2\sin^{-1}x$$

Derivative of $\frac{1}{2}\tan^{-1}x$ w.r.to $2\sin^{-1}x$

$$= \frac{1}{2(1+x^2)} \times \frac{\sqrt{1-x^2}}{2} = \frac{\sqrt{3}}{10}, \text{ at } x = \frac{1}{2}$$

2. If the system of linear equations

$$x + y + 3z = 0$$

$$x + 3y + k^2z = 0$$

$$3x + y + 3z = 0$$

has a non-zero solution (x, y, z) for some $k \in \mathbb{R}$, then $x + \left(\frac{y}{z}\right)$ is equal to :

- 1) 3 2) 9 3) -3 4) -9

Key: 3

Sol: Homogenous equations, having non zero solution satisfy

$$\begin{vmatrix} 1 & 1 & 3 \\ 1 & 3 & k^2 \\ 3 & 1 & 3 \end{vmatrix} = 0$$

$$\begin{vmatrix} 1 & 1 & 3 \\ 1 & 3 & k^2 \\ 2 & 0 & 0 \end{vmatrix} = 0 \quad R_3 \rightarrow R_3 - R_1$$

From R_3 , $2x = 0 \Rightarrow x = 0$

From R_1 , $y + 3z = 0 \Rightarrow \frac{y}{z} = -3$

$\therefore x + \frac{y}{z} = -3$ which also satisfy R_2 for $k^2 = 9$

3. There are 3 sections in a question paper and each section contains 5 questions. A candidate has to answer a total of 5 questions, choosing at least one question from each section. Then the number of ways, in which the candidate can choose the questions, is:

- 1) 1500 2) 2255 3) 3000 4) 2250

Key: 4

Sol:

$$\begin{matrix} A(5) & B(5) & C(5) \\ 1 & 1 & 3 \\ 2 & 2 & 1 \end{matrix}$$

(1,1,3) in ${}^5C_1 \times {}^5C_1 \times {}^5C_3 \times 3$ ways = 750

(2,2,1) in ${}^5C_2 \times {}^5C_2 \times {}^5C_1 \times 3$ ways = 1500

\therefore total ways = 2250

4. If $\int \frac{\cos \theta}{5 + 7 \sin \theta - 2 \cos^2 \theta} d\theta = A \log_e |B(\theta)| + C$, Where C is a constant of integration, then

$\frac{B(\theta)}{A}$ can be

- 1) $\frac{5(2 \sin \theta + 1)}{\sin \theta + 3}$ 2) $\frac{2 \sin \theta + 1}{\sin \theta + 3}$ 3) $\frac{5(\sin \theta + 3)}{2 \sin \theta + 1}$ 4) $\frac{2 \sin \theta + 1}{5(\sin \theta + 3)}$

Key: 1

Sol: Put $\sin \theta = t$

$$\cos \theta d\theta = dt$$

$$\int \frac{dt}{3+7t+2t^2} = \int \frac{dt}{(2t+1)(t+3)}$$

$$= \frac{1}{5} \int \left(\frac{2}{2t+1} - \frac{1}{t+3} \right) dt$$

$$= \frac{1}{5} \log_e \left(\frac{2 \sin \theta + 1}{\sin \theta + 3} \right) + c$$

$$\therefore \frac{B(\theta)}{A} = \frac{5(2 \sin \theta + 1)}{\sin \theta + 3}$$

5. If $x=1$ is a critical point of the function $f(x) = (3x^2 + ax - 2 - a)e^x$, then:

1) $x=1$ is a local minima and $x = -\frac{2}{3}$ is a local maxima of f

2) $x=1$ and $x = -\frac{2}{3}$ are local minima of f

3) $x=1$ is a local maxima and $x = -\frac{2}{3}$ is a local minima of f

4) $x=1$ and $x = -\frac{2}{3}$ are local maxima of f

Key: 1

Sol: $f'(x) = (3x^2 + ax - 2 - a)e^x + (6x + a)e^x$

$$f''(x) = (3x^2 + ax - 2 - a + 6x + a)e^x + (6x + a + 6)e^x$$

$$f''(1) = f'(1) + (12 + a)e$$

$$= 0 + (12 + a)e (\because x=1 \text{ is critical point})$$

$\therefore x=1$ is a local minimum

Since $f(x)$ is continuous function,

$x = -\frac{2}{3}$ is local maximum.

6. If the length of the chord of the circle, $x^2 + y^2 = r^2$ ($r > 0$) along the line, $y - 2x = 3$ is r , then r^2 is equal to

1) $\frac{12}{5}$

2) 12

3) $\frac{9}{5}$

4) $\frac{24}{5}$

Key: 1

Sol:

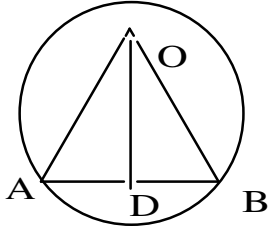
Centre $O = (0,0)$ $OA = OB = r = AB$ \therefore triangle OAB is equilateralEquation of AB is $y-2x=3$ $\therefore OD = \perp$ distance from D to AB = $\frac{3}{\sqrt{5}}$

$$\sin 60^\circ = \frac{OD}{OA} \Rightarrow r^2 = \frac{12}{5}$$

7. If the mean and the standard deviation of the data 3,5,7,a,b are 5 and 2 respectively, then a and b are the roots of the equation:

1) $x^2 - 10x + 19 = 0$

2) $x^2 - 10x + 18 = 0$

3) $x^2 - 20x + 18 = 0$

4) $2x^2 - 20x + 19 = 0$

Key: 1

Sol: Mean = 5 $\Rightarrow \frac{3+5+7+a+b}{5} = 5$

$\Rightarrow a+b=10$ _____ (1)

S.D=2 \Rightarrow variance = 4

$$\frac{9+25+49+a^2+b^2}{5} - (5)^2 = 4$$

$a^2+b^2 = 62$

$ab = 19$ (\because from (1))

 \therefore a, b are roots of the equation

$x^2 - 10x + 19 = 0$

8. If for some $\alpha \in \mathbb{R}$, the lines $L_1 : \frac{x+1}{2} = \frac{y-2}{-1} = \frac{z-1}{1}$ and $L_2 : \frac{x+2}{\alpha} = \frac{y+1}{5-\alpha} = \frac{z+1}{1}$ are coplanar,

then the line L_2 passes through the point:

1) $(-2, 10, 2)$

2) $(10, -2, -2)$

3) $(2, -10, -2)$

4) $(10, 2, 2)$

Key: 3

Sol: $A = (-1, 2, 1), C = (-2, -1, -1)$

L_1, L_2 are coplanar

$$\Rightarrow \begin{vmatrix} -1+2 & 2+1 & 1+1 \\ 2 & -1 & 1 \\ \alpha & 5-\alpha & 1 \end{vmatrix} = 0 \Rightarrow \alpha = -4$$

Equation of L_2 is

$$\frac{x+2}{-4} = \frac{y+1}{9} = \frac{z+1}{1} = t$$

Any point on L_2 is

$$(-4t-2, 9t-1, t-1) = (2, -10, -2), \text{ for } t = -1$$

9. The area (in sq. units) of the region $A = \{(x, y) : (x-1)[x] \leq y \leq 2\sqrt{x}, 0 \leq x \leq 2\}$ where $[t]$ denotes the greatest integer function, is:

- 1) $\frac{4}{3}\sqrt{2}+1$ 2) $\frac{8}{3}\sqrt{2}-\frac{1}{2}$ 3) $\frac{8}{3}\sqrt{2}-1$ 4) $\frac{4}{3}\sqrt{2}-\frac{1}{2}$

Key: 2

Sol: If $0 \leq x < 1, [x] = 0$

A is $\{(x, y) : 0 \leq y \leq 2\sqrt{x}\}$

If $1 \leq x < 2, [x] = 1$

A is $\{(x, y) : x-1 \leq y \leq 2\sqrt{x}\}$

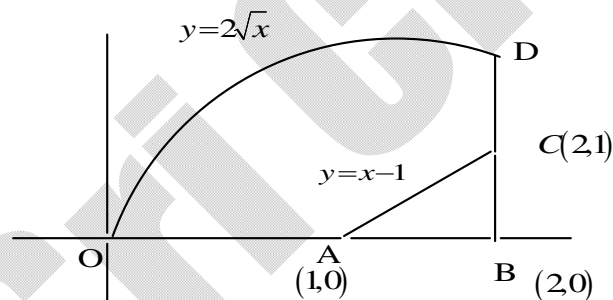

$$\text{Area} = \int_0^2 2\sqrt{x} dx - \text{Area of } \triangle ABC = \frac{8\sqrt{2}}{3} - \frac{1}{2} \times 1 \times 1$$

$$x \left(e^{\left(\frac{\sqrt{1+x^2+x^4}-1}{x} \right)} - 1 \right)$$

10. $\lim_{x \rightarrow 0} \frac{x \left(e^{\left(\frac{\sqrt{1+x^2+x^4}-1}{x} \right)} - 1 \right)}{\sqrt{1+x^2+x^4}-1}$

1) is equal to 0

2) does not exist

3) is equal to 1

4) is equal to \sqrt{e}

Key: 3

$$\text{Sol: } \lim_{x \rightarrow 0} \frac{x(e^{\frac{1+x^2+x^4-1}{\sqrt{1+x^2+x^4+1}}} - 1)}{1+x^2+x^4-1}$$

$$\lim_{x \rightarrow 0} \frac{e^{f(x)} - 1}{f(x)}, \quad \text{where } f(x) = \frac{x+x^3}{\sqrt{1+x^2+x^4+1}} \rightarrow 0, \text{ as } x \rightarrow 0$$

11. If α and β are the roots of the equation, $7x^2 - 3x - 2 = 0$, then the value of

$$\frac{\alpha}{1-\alpha^2} + \frac{\beta}{1-\beta^2} \text{ is equal to:}$$

- 1) $\frac{27}{16}$ 2) $\frac{3}{8}$ 3) $\frac{1}{24}$ 4) $\frac{27}{32}$

Key: 1

$$\text{Sol: } \alpha + \beta = \frac{3}{7}, \alpha\beta = -\frac{2}{7}$$

$$\alpha^2 + \beta^2 = \frac{9}{49} + \frac{4}{7} = \frac{37}{49}$$

$$\frac{\alpha}{1-\alpha^2} + \frac{\beta}{1-\beta^2} = \frac{\alpha + \beta - \alpha\beta(\alpha + \beta)}{1 - (\alpha^2 + \beta^2) + (\alpha\beta)^2}$$

$$= \frac{\frac{3}{7} + \frac{6}{49}}{1 - \frac{37}{49} + \frac{4}{49}} = \frac{27}{16}$$

12. The value of $\left(\frac{-1+i\sqrt{3}}{1-i}\right)^{30}$ is

- 1) -2^{15} 2) $-2^{15}i$ 3) $2^{15}i$ 4) 6^5

Key: 2

Sol: $-1+i\sqrt{3} = 2w$, w is cube root of 1

$$(-1+i\sqrt{3})^{30} = 2^{30} w^{30} = 2^{30}$$

$$(1-i)^2 = 1+i^2 - 2i = -2i$$

$$(1-i)^{30} = (-2i)^{15} = -2^{15}(-i) = 2^{15}i$$

$$\left(\frac{-1+i\sqrt{3}}{1-i}\right)^{30} = \frac{2^{30}}{2^{15}i} = 2^{15}(-i)$$

13. If the sum of the first 20 terms of the series $\log_{(7^{1/2})} x + \log_{(7^{1/3})} x + \log_{(7^{1/4})} x + \dots$ is 460, then x is equal to
- 1) $7^{1/2}$ 2) $7^{46/21}$ 3) e^2 4) 7^2

Key: 4

Sol: $2\log_7^x + 3\log_7^x + 4\log_7^x + \dots = 460$
 (20 terms)
 $(2+3+4+\dots)\log_7^x = 460$
 $\left(\frac{21 \times 22}{2} - 1\right)\log_7^x = 460$
 $\log_7^x = 2 \Rightarrow x = 7^2$

14. Which of the following points lies on the tangent to the curve $x^4 e^y + 2\sqrt{y+1} = 3$ at the point (1,0)?
- 1) (-2,6) 2) (-2,4) 3) (2,2) 4) (2,6)

Key: 1

Sol: $x^4 e^y + 2\sqrt{y+1} = 3$
 Differentiating w.r.t 'x'
 $x^4 e^y y^1 + 4x^3 e^y + \frac{1}{\sqrt{y+1}} y^1 = 0$
 $y^1 + 4 + y^1 = 0, \text{ at } (1,0)$
 $\therefore y^1 = -2$
 Equation of tangent at (1,0) is
 $y = -2(x-1)$
 $2x + y = 2$
 $\therefore (-2,6)$ lies on this line

15. The statement $(p \rightarrow (q \rightarrow p)) \rightarrow (p \rightarrow (p \vee q))$ is
- 1) a contradiction 2) a tautology
 3) equivalent to $(p \wedge q) \vee (\sim q)$ 4) equivalent to $(p \vee q) \wedge (\sim p)$

Key: 2

Sol: $p \rightarrow (q \rightarrow p)$ is always T $p \rightarrow (p \vee q)$ is always T $\therefore (p \rightarrow (q \rightarrow p)) \rightarrow (p \rightarrow (p \vee q))$ is always T \therefore tautology16. Let $y = y(x)$ be the solution of the differential equation

$$\cos x \frac{dy}{dx} + 2y \sin x = \sin 2x, x \in \left(0, \frac{\pi}{2}\right). \text{ If } y\left(\frac{\pi}{3}\right) = 0 \text{ then } y\left(\frac{\pi}{4}\right) =$$

- 1) $2 + \sqrt{2}$ 2) $2 - \sqrt{2}$ 3) $\sqrt{2} - 2$ 4) $\frac{1}{\sqrt{2}} - 1$

Key: 3

Sol:
$$\frac{dy}{dx} + (2 \tan x) y = 2 \sin x$$

I.F. = $e^{\int 2 \tan x dx} = \sec^2 x$

$$\therefore y \sec^2 x = \int 2 \sin x \sec^2 x dx = \int 2 \sec x \tan x dx$$

$$= 2 \sec x + c$$

$$y = 2 \cos x + c \cos^2 x$$

$$y\left(\frac{\pi}{3}\right) = 0 \Rightarrow c = -4 \quad \therefore y = 2 \cos x - 4 \cos^2 x \quad \therefore y\left(\frac{\pi}{4}\right) = \sqrt{2} - 2$$

17. If the line $y = mx + c$ is a common tangent to the hyperbola $\frac{x^2}{100} - \frac{y^2}{64} = 1$ and the circle

$$x^2 + y^2 = 36, \text{ then which one of the following is true?}$$

- 1) $c^2 = 369$ 2) $4c^2 = 369$ 3) $5m = 4$ 4) $8m + 5 = 0$

Key: 2

Sol: $y = mx + c$ is tangent to hyperbola

$$\Rightarrow c^2 = a^2 m^2 - b^2 = 100m^2 - 64$$

 $y = mx + c$ is tangent to circle

$$\Rightarrow c^2 = r^2(1 + m^2) = 36(1 + m^2) \quad \therefore 100m^2 - 64 = 36 + 36m^2$$

$$m^2 = \frac{25}{16} \quad c^2 = \frac{369}{4} \Rightarrow 4c^2 = 369$$

18. If the sum of the second, third and fourth terms of a positive term G.P. is 3 and the sum of its sixth, seventh and eighth terms is 243, then the sum of the first 50 terms of this G.P is

- 1) $\frac{1}{13}(3^{50}-1)$ 2) $\frac{1}{26}(3^{49}-1)$ 3) $\frac{2}{13}(3^{50}-1)$ 4) $\frac{1}{26}(3^{50}-1)$

Key: 4

Sol: $ar(1+r+r^2)=3$ _____ (1)

$$ar^5(1+r+r^2)=243$$

$$\therefore r^4 = \frac{243}{3} = 81 \Rightarrow r = 3$$

From(1), $a = \frac{1}{13}$

$$\therefore S_{50} = \frac{1}{13} \frac{(3^{50}-1)}{3-1} = \frac{1}{26}(3^{50}-1)$$

19. If $L = \sin^2\left(\frac{\pi}{16}\right) - \sin^2\left(\frac{\pi}{8}\right)$ and $M = \cos^2\left(\frac{\pi}{16}\right) - \sin^2\left(\frac{\pi}{8}\right)$, then

- 1) $M = \frac{1}{4\sqrt{2}} + \frac{1}{4} \cos \frac{\pi}{8}$ 2) $L = -\frac{1}{2\sqrt{2}} + \frac{1}{2} \cos \frac{\pi}{8}$
 3) $M = \frac{1}{2\sqrt{2}} + \frac{1}{2} \cos \frac{\pi}{8}$ 4) $L = \frac{1}{4\sqrt{2}} - \frac{1}{4} \cos \frac{\pi}{8}$

Key: 2

Sol: $L = \frac{1}{2} \left(1 - \cos \frac{\pi}{8}\right) - \frac{1}{2} \left(1 - \cos \frac{\pi}{4}\right) = \frac{1}{2\sqrt{2}} - \frac{1}{2} \cos \frac{\pi}{8}$

$$M = \frac{1}{2} \left(1 + \cos \frac{\pi}{8}\right) - \frac{1}{2} \left(1 - \cos \frac{\pi}{4}\right) = \frac{1}{2\sqrt{2}} + \frac{1}{2} \cos \frac{\pi}{8}$$

20. If $a+x=b+y=c+z+1$, where a, b, c, x, y, z are non-zero distinct real numbers, then

$$\begin{vmatrix} x & a+y & x+a \\ y & b+y & y+b \\ z & c+y & z+c \end{vmatrix} \text{ is equal to}$$

- 1) $y(a-c)$ 2) 0 3) $y(a-b)$ 4) $y(b-a)$

Key: 3

$$\begin{aligned}
 \text{Sol: } & \begin{vmatrix} x & a+y & x+a \\ y & b+y & y+b \\ z & c+y & z+c \end{vmatrix} \\
 &= \begin{vmatrix} x & a+y & a \\ y & b+y & b \\ z & c+y & c \end{vmatrix} C_3 \rightarrow C_3 - C_1 \\
 &= \begin{vmatrix} x & y & a \\ y & y & b \\ z & y & c \end{vmatrix} C_2 \rightarrow C_2 - C_3 \\
 &= \begin{vmatrix} x+a & y & a \\ y+b & y & b \\ z+c & y & c \end{vmatrix} C_1 \rightarrow C_1 + C_3 \\
 &= \begin{vmatrix} y+b & y & a \\ y+b & y & b \\ y+b-1 & y & c \end{vmatrix} (\because \text{data}) \\
 &= \begin{vmatrix} 0 & 0 & a-b \\ 1 & 0 & b-c \\ y+b-1 & y & c \end{vmatrix} = (a-b)y
 \end{aligned}$$

(NUMERICAL VALUE TYPE)

This section contains 5 questions. Each question is numerical value. For each question, enter the correct numerical value (in decimal notation, truncated/ rounded-off to second decimal place.(e.g. 6.25, 7.00, -0.33, -.30, 30.27, -127.30).

Marking scheme: +4 for correct answer, 0 if not attempted and 0 in all other cases.

21. The coefficient of x^4 in the expansion of $(1+x+x^2+x^3)^6$ in powers of x , is _____

Key: 120

$$\begin{aligned}
 \text{Sol: } & (1+x^2)^6 (1+x)^6 \\
 & (1+6C_1x^2+6C_2x^4+\dots)(1+6C_1x+6C_1x^2+6C_3x^3+6C_4x^4+\dots) \\
 & \text{Coefficient of } x^4 \\
 & = 6C_4 + 6C_1 \times 6C_2 + 6C_2 \\
 & = 15 + (6 \times 15) + 15 = 120
 \end{aligned}$$

22. Let $A = \{a, b, c\}$ and $B = \{1, 2, 3, 4\}$. Then the number of elements in the set

$$C = \{f : A \rightarrow B \mid 2 \in f(A) \text{ and } f \text{ is not one-one}\} \text{ is } \underline{\hspace{2cm}}$$

Key: 19

Sol: If range of $f = \{2\} \rightarrow 1$ function

If Range of $f = \{1,2\}$ or $\{2,3\}$ or $\{2,4\}$

Number of functions $= 3(2^3 - 2) = 18$

\therefore total functions in $C = 1 + 18 = 19$

23. If the lines $x + y = a$ and $x - y = b$ touch the curve $y = x^2 - 3x + 2$ at the points where the curve intersects the x-axis, then $\frac{a}{b}$ is equal to _____

Key: 0.5

Sol: $y = x^2 - 3x + 2 = (x-1)(x-2)$, intersects x axis at (1,0), (2,0)

$x + y = a \Rightarrow 1 + 0 = a$

$x - y = b \Rightarrow 2 - 0 = b$

$\therefore \frac{a}{b} = \frac{1}{2} = 0.5$

24. In a bombing attack, there is 50% chance that a bomb will hit the target. At least two independent hits are required to destroy the target completely. Then the minimum number of bombs that must be dropped to ensure that there is at least 99% chance of completely destroying the target, is _____

Key: 11

Sol: $p =$ Probability of bomb hit the target $= \frac{1}{2}$, $q = \frac{1}{2}$

Let n bombs are required for $P(x \geq 2) \geq \frac{99}{100}$

$1 - P(x = 0, 1) \geq \frac{99}{100}$

$p(x = 0) + p(x = 1) \leq \frac{1}{100}$

$\left(\frac{1}{2}\right)^n + {}^n C_1 \left(\frac{1}{2}\right)^n \leq \frac{1}{100}$

$100(n+1) \leq 2^n$

\therefore minimum value of $n = 11$

25. Let the vectors $\vec{a}, \vec{b}, \vec{c}$ be such that $|\vec{a}| = 2, |\vec{b}| = 4$ and $|\vec{c}| = 4$. If the projection of \vec{b} on \vec{a} is equal to the projection of \vec{c} on \vec{a} and \vec{b} is perpendicular to \vec{c} , then the value of $|\vec{a} + \vec{b} - \vec{c}|$ is _____

Key: 6

Sol: $\frac{\vec{a} \cdot \vec{b}}{|\vec{a}|} = \frac{\vec{a} \cdot \vec{c}}{|\vec{a}|} \Rightarrow \vec{a} \cdot (\vec{b} - \vec{c}) = 0$

$$|\vec{a} + \vec{b} - \vec{c}|^2 = a^2 + b^2 + c^2 + 2\vec{a} \cdot (\vec{b} - \vec{c}) - 2\vec{b} \cdot \vec{c}$$

$$= 4 + 16 + 16 + 0 - 0$$

$$= 36 \quad (\because \vec{b} \perp \vec{c})$$

$$|\vec{a} + \vec{b} - \vec{c}| = 6$$

Prepared by

Sri Chaitanya Faculty