



Sri Chaitanya
Educational Institutions

Infinity
Learn



Sri Chaitanya
Techno School

The right mentor for IIT (JEE), NEET, Olympiad & all Other Competitive exams



PERFECT SCORE.

Excellence has a permanent address
- Sri Chaitanya.

JEE Main 2026 (Session 1)



300
300

PASALA MOHITH

Appl.No: 260310432915

CLASSROOM STUDENT

🎉 Congratulations To Parents, Teachers & Staff 🎉

#TransformingYourDreamsIntoReality



www.srichaitanya.net



040-66 06 06 06



Sri Chaitanya
Educational Institutions

Infinity
Learn



JEE MAIN 2026 - SESSION 1

21-01-2026 - Shift 1

**TOPPERS ARE NOT BORN,
THEY'RE MADE @ SRI CHAITANYA**

JEE MAIN 2025



AJAY REDDY VANGALA
HT. NO. 250310255592
CLASSROOM STUDENT FROM GRADE IX-XII

JEE ADV 2025



D. GNANA RUTVIK SAI
HT. NO. 256055278*

NEET 2025



KAVISH
HT. NO. 250411147966*
CLASSROOM STUDENT

**SCAN FOR
ADMISSIONS**



Call Us Now: **040-66 06 06 06**

www.srichaitanya.net

Follow us    

#TransformingYourDreamsIntoReality



21-Jan-2026_Shift-I_JEE Main-2026_Session-I (Jan)

MATHEMATICS

Max Marks: 100

Section-I

(SINGLE CORRECT ANSWER TYPE)

This section contains **20 Multiple Choice Questions**. Each question has 4 options (1), (2), (3) and (4) for its answer, out of which **ONLY ONE** option can be correct.

Marking scheme: +4 for correct answer, 0 if not attempted and -1 in all other cases.

1. The value of $\int_{-\pi/6}^{\pi/6} \frac{\pi + 4x^{11}}{1 - \sin\left(|x| + \frac{\pi}{6}\right)} dx$ is equal to

- 1) 8π 2) 2π 3) 6π 4) 4π

Key: 4

Sol: $\int_{-\pi/6}^{\pi/6} (\pi + 4x^{11}) / (1 - \sin(|x| + \pi/6)) dx$

$$= \int_0^{\pi/6} 2\pi / (1 - \sin(|x| + \pi/6)) dx$$

$$\text{Let } x + \pi/6 = \theta \Rightarrow dx = d\theta$$

$$= 2\pi \int_{\pi/6}^{\pi/3} d\theta / (1 - \sin\theta) = 2\pi \int_{\pi/6}^{\pi/3} (1 + \sin\theta) / \cos^2\theta d\theta$$

$$= 2\pi \int_{\pi/6}^{\pi/3} (\sec^2\theta + \sec\theta \tan\theta) d\theta = 2\pi [\tan\theta + \sec\theta]_{\pi/6}^{\pi/3}$$

$$= 2\pi [(\sqrt{3} + 2) - (1\sqrt{3} + 2/\sqrt{3})] = 2\pi [2] = 4\pi$$

2. The sum of all roots of equation $(x-1)^2 - 5|x-1| + 6 = 0$ is

- 1) 4 2) 1 3) 5 4) 3

Key : 1

Sol: $(x-1)^2 - 5|x-1| + 6 = 0$

$$\text{Let } |x-1| = t$$

$$t^2 - 5t + 6 = 0$$

$$t = 2 \text{ or } 3$$

$$|x-1| = 2 \text{ or } 3$$

$$x-1 = \pm 2 \text{ or } \pm 3$$

$$x = 1 \pm 2 \text{ or } 1 \pm 3$$

$$\text{Sum of roots} = 4$$

3. The value of $\operatorname{cosec}10^\circ - \sqrt{3}\sec10^\circ$ is equal to

- 1) 8 2) 6 3) 4 4) 2

Key : 3

$$\begin{aligned} \text{Sol: } \operatorname{cosec}10^\circ - \sqrt{3}\sec10^\circ &= \frac{1}{\sin10^\circ} - \frac{\sqrt{3}}{\cos10^\circ} = \frac{\cos10^\circ - \sqrt{3}\sin10^\circ}{\sin10^\circ \cdot \cos10^\circ} \\ &= \frac{\frac{1}{2} \cdot \cos10^\circ - \frac{\sqrt{3}}{2} \sin10^\circ}{2\sin10^\circ \cos10^\circ} \cdot 4 = \frac{\sin(30^\circ - 10^\circ)}{\sin20^\circ} \cdot 4 = 4 \end{aligned}$$

4. If $x^2 + x + 1 = 0$, then the value of $\left(x + \frac{1}{x}\right)^4 + \left(x^2 + \frac{1}{x^2}\right)^4 + \left(x^3 + \frac{1}{x^3}\right)^4 + \dots + \left(x^{25} + \frac{1}{x^{25}}\right)^4$ is

- 1) 145 2) 162 3) 175 4) 128

Key : 1

$$\begin{aligned} \text{Sol: } x^2 + x + 1 = 0 \Rightarrow x = w \\ \left(x + \frac{1}{x}\right)^4 + \left(x^2 + \frac{1}{x^2}\right)^4 + \left(x^3 + \frac{1}{x^3}\right)^4 + \dots + \left(x^{25} + \frac{1}{x^{25}}\right)^4 \\ = (1+1+16) + (1+1+16) + \dots + 8 \text{ triplets} + 1 \\ = 8(18) + 1 = 145 \end{aligned}$$

5. Let a_1, a_2, a_3, \dots be a G.P of increasing positive terms such that

$$a_2 \cdot a_3 \cdot a_4 = 64 \text{ \& } a_1 + a_3 + a_5 = \frac{813}{7} \text{ then } a_3 + a_5 + a_7 \text{ is equal to}$$

- 1) 3256 2) 3252 3) 3248 4) 3244

Key : 2

$$\begin{aligned} \text{Sol: } a_2 \cdot a_3 \cdot a_4 &= 64 \\ (ar)(ar^2)(ar^3) &= 64 \\ a^3 r^6 &= 64 \\ ar^2 &= 4 \\ a_1 + a_3 + a_5 &= \frac{813}{7} \\ a + ar^2 + ar^4 &= \frac{813}{7} \\ a(1+r^4) &= \frac{813}{7} - 4 \\ a(1+r^4) &= \frac{785}{7} \\ \frac{a(1+r^4)}{ar^2} &= \frac{785}{7} \times \frac{1}{4} \\ \frac{1+r^4}{r^2} &= \frac{785}{28} \\ 28r^4 + 28 &= 785r^2 \end{aligned}$$

$$28r^4 - 785r^2 + 28 = 0$$

$$28r^4 - 784r^2 - r^2 + 28 = 0$$

$$28r^2(r^2 - 28) - 1(r^2 - 28) = 0$$

$$(r^2 - 28)(28r^2 - 1) = 0$$

$$r^2 = 28 \text{ or } r^2 = \frac{1}{28} \text{ (Rejected)}$$

$$ar^2 = 4 \Rightarrow a = \frac{4}{28} = \frac{1}{7}$$

$$a_3 + a_5 + a_7 = ar^2 + ar^4 + ar^6 = ar^2(1 + r^2 + r^4) = 4(1 + 28 + 784) = 4(813) = 3252$$

6. The number of relations, defined on the set $\{a, b, c, d\}$ which are both reflexive & symmetric is equal to

1) 16

2) 1024

3) 64

4) 256

Key: 3

Sol: No. of ways = $1.2^6.1 = 64$

7. Let $y = y(x)$ be the solution curve of the differential equation $((1+x^2)dy + (y - \tan^{-1}x)dx = 0$
 $y(0) = 1$ then value of $y(1)$ is

1) $\frac{4}{e^{\pi/4}} - \pi/2 - 1$

2) $\frac{2}{e^{\pi/4}} + \pi/4 - 1$

3) $\frac{2}{e^{\pi/4}} - \pi/4 - 1$

4) $\frac{4}{e^{\pi/4}} + \pi/2 - 1$

Key: 2

Sol: $(1+x^2)dy + (y - \tan^{-1}x)dx = 0$

$$(1+x^2) \frac{dy}{dx} + y - \tan^{-1}x = 0$$

$$\frac{dy}{dx} + y \cdot \left(\frac{1}{1+x^2} \right) = \frac{\tan^{-1}x}{1+x^2}$$

$$\text{I.F} = e^{\int \frac{1}{1+x^2} dx} = e^{\tan^{-1}x}$$

$$y \cdot \text{I.F} = \int (\text{I.F}) \cdot Q(x) dx$$

$$y \cdot e^{\tan^{-1}x} = \int e^{\tan^{-1}x} \cdot \frac{\tan^{-1}x}{1+x^2} dx$$

$$= \int e^t \cdot t \cdot dt \quad \tan^{-1}x = t$$

$$= t \cdot e^t - \int 1 \cdot e^t \frac{1}{1+x^2} dx = dt = t \cdot e^t - e^t + c$$

$$y \cdot e^{\tan^{-1}x} = e^{\tan^{-1}x} (\tan^{-1}x - 1) + c$$

$$y = (\tan^{-1}x - 1) + \frac{C}{e^{\tan^{-1}x}}$$

$$x = 0, y = 1, 1 = (0 - 1) + \frac{C}{1}$$

$$C = 2$$

$$y = (\tan^{-1}x - 1) + \frac{2}{e^{\tan^{-1}x}}, \quad x = 1 \Rightarrow y(1) = \frac{\pi}{4} - 1 + \frac{2}{e^{\pi/4}}$$

8. Let a point A lie between the parallel lines L_1 and L_2 such that its distances from L_1 and L_2 are 6 and 3 units respectively then the area (in sq units) of equilateral triangle ABC where the Points B and C lie on lines L_1 and L_2 respectively is

- 1) $21\sqrt{3}$ 2) $15\sqrt{6}$ 3) $12\sqrt{2}$ 4) 27

Key : 1

Sol:

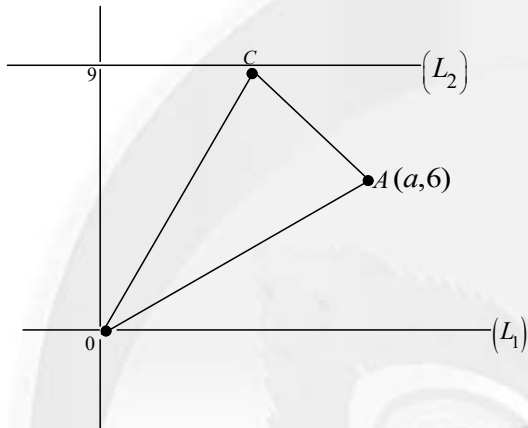

Take $L_1 : y=0$

$L_2 : y=9$

Take B is at origin

Let $A = (a, 6)$, $B(0, 0)$

$C = (b, 9)$

$\triangle ABC$ is equilateral

$$(b, 9) = \frac{x_1 + x_2 \pm \sqrt{3}(y_1 - y_2)}{2}, \frac{y_1 + y_2 \pm \sqrt{3}(x_1 - x_2)}{2}$$

$$= \left(\frac{a + 0 \pm \sqrt{3}(6 - 0)}{2}, \frac{6 + 0 \pm \sqrt{3}(a - 0)}{2} \right) = \left(\frac{a + 6\sqrt{3}}{2}, \frac{6 - \sqrt{3}a}{2} \right) \text{ or } \left(\frac{a - 6\sqrt{3}}{2}, \frac{6 + \sqrt{3}a}{2} \right)$$

$$\text{If } \frac{6 + \sqrt{3}a}{2} = 9 \Rightarrow 6 + \sqrt{3}a = 18$$

$$+12 = \sqrt{3}a$$

$$a = +4\sqrt{3}$$

$$b = \frac{a - 6\sqrt{3}}{2} = -\sqrt{3}$$

$$\text{Area} = \frac{1}{2} |x_1 y_2 - x_2 y_1| = \frac{1}{2} |9a - 6b| = \frac{1}{2} |36\sqrt{3} + 6\sqrt{3}| = 21\sqrt{3}$$

OR

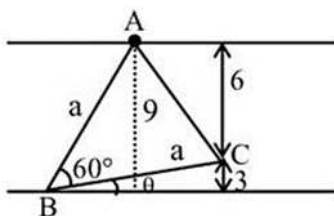

$$\sin \theta = \frac{3}{a} \quad \sin(60^\circ + \theta) = \frac{9}{a}$$

$$\frac{\sqrt{3}}{2} \cos \theta + \frac{1}{2} \sin \theta = \frac{9}{a}$$

$$\sqrt{3} \sqrt{1 - \frac{9}{a^2}} + \frac{3}{a} = \frac{18}{a} \quad a = \sqrt{84}$$

$$\text{Area of } \triangle ABC = \frac{\sqrt{3}}{4} a^2 = \frac{\sqrt{3}}{4} \times 84 = 21\sqrt{3}$$

9. Let foci of a hyperbola coincide with the foci of the ellipse $\frac{x^2}{36} + \frac{y^2}{16} = 1$ if eccentricity of the hyperbola is 5 then length of its latus rectum is

- 1) 16 2) $24\sqrt{5}$ 3) $\frac{96}{\sqrt{5}}$ 4) 12

Key : 3

Sol: Ellipse $\frac{x^2}{36} + \frac{y^2}{16} = 1$

$$e_E = \sqrt{\frac{36-16}{36}} = \frac{\sqrt{20}}{6}$$

$$\text{Foci} = \left(6 \cdot \frac{\sqrt{20}}{6}, 0\right), \left(-6 \cdot \frac{\sqrt{20}}{6}, 0\right) = (\sqrt{20}, 0), (-\sqrt{20}, 0)$$

Hyperbola : $\frac{x^2}{a^2} - \frac{y^2}{b^2} = 1$

$$ae_H = \sqrt{20}$$

$$5a = \sqrt{20} = 2\sqrt{5}$$

$$a = \frac{2}{\sqrt{5}}$$

$$b^2 = a^2(e^2 - 1)$$

$$b^2 = \frac{4}{5}(25 - 1) = \frac{96}{5}$$

$$LLR = \frac{2b^2}{a} = 2 \cdot \frac{96}{5} \cdot \frac{\sqrt{5}}{2} = \frac{96}{\sqrt{5}}$$

10. Let $f : \mathbb{R} \rightarrow (0, \infty)$ be a twice differentiable function such that

$$f(3) = 18, f'(3) = 0 \text{ and } f(3) = 4 \text{ then } \lim_{x \rightarrow 1} \left[\log_e \left(\frac{f(2+x)}{f(3)} \right)^{\frac{18}{(x-1)^2}} \right] \text{ is equal to}$$

- 1) 1 2) 18 3) 2 4) 9

Key : 3

Sol: $\ln \left[\lim_{x \rightarrow 1} \left(\frac{f(2+x)}{f(3)} \right)^{\frac{18}{(x-1)^2}} \right] = \lim_{x \rightarrow 1} \frac{18}{(x-1)^2} \left[\frac{f(2+x)}{f(3)} - 1 \right] = \lim_{x \rightarrow 1} \left[\frac{f(2+x) - 18}{18} \right] \cdot \frac{18}{(x-1)^2}$

$$= \lim_{x \rightarrow 1} \frac{f'(2+x)}{2(x-1)} = \lim_{x \rightarrow 1} \frac{f''(2+x)}{2} = \frac{f''(3)}{2} = \frac{4}{2} = 2$$

11. The number of strictly increasing functions f from set $\{1,2,3,4,5,6\}$ to the set $\{1,2,3,\dots,9\}$ such that $f(i) \neq i$ for $1 \leq i \leq 6$ is equal to

- 1) 21 2) 27 3) 22 4) 28

Key : 4

Sol: No. of functions = ${}^8C_6 = {}^8C_2 = 28$

12. Let $\vec{a} = -i + 2j + 2\vec{k}$, $\vec{b} = 8i + 7j - 3k$ and c be a vector such that $a \times c = \vec{b}$ if $c \cdot (i + j + k) = 4$ then

$|a + c|^2$ is equal to

- 1) 30 2) 27 3) 33 4) 35

Key : 2

Sol: $\vec{a} = -i + 2j + 2\vec{k}$

$\vec{b} = 8i + 7j - 3k$

Let $\vec{c} = xi + yj + zk$

$$\vec{a} \times \vec{c} = \begin{vmatrix} \vec{i} & \vec{j} & \vec{k} \\ -1 & 2 & 2 \\ x & y & z \end{vmatrix}$$

$$\vec{b} = \vec{i}(2z - 2y) - \vec{j}(-z - 2x) + \vec{k}(-y - 2x)$$

$$2z - 2y = 8 \rightarrow (1), \quad 2x - z = 7 \rightarrow (2), \quad -y - 2x = -3 \rightarrow (3)$$

Solving $-y + z = 4$

$$x + y + z = 4$$

$$x + 2z = 8$$

$$2x + 4z = 16$$

$$2x + z = 7$$

$$3z = 9$$

$$z = 3$$

$$-y + 3 = 4 \Rightarrow y = -1$$

$$2x + 3 = 7$$

$$x = 2$$

$$\vec{a} + \vec{c} = (-i + 2j + 2k) + (2i - j + 3k) = i + j + 5k$$

$$|\bar{a} + \bar{c}| = \sqrt{1+1+25} = \sqrt{27} \quad |a+c|^2 = 27$$

13. If the domain of the function $f(x) = \cos^{-1}\left(\frac{2x-5}{11-3x}\right) + \sin^{-1}(2x^2 - 3x + 1)$ is the interval $[\alpha, \beta]$,

then $\alpha + 2\beta$ is equal to

- 1) 5 2) 1 3) 3 4) 2

Key: 3

Sol: $-1 \leq \frac{2x-5}{11-3x} \leq 1, 11-3x \neq 0, -1 \leq 2x^2 - 3x + 1 \leq 1$

$$\frac{2x-5}{11-3x} + 1 \geq 0, \frac{2x-5}{11-3x} - 1 \leq 0, x \neq \frac{11}{3}$$

$$2x^2 - 3x + 2 \geq 0, 2x^2 - 3x \leq 0$$

$$\frac{2x-5+11-3x}{11-3x} \geq 0, \frac{2x-5-11+3x}{11-3x} \leq 0, x \neq \frac{11}{3}, x \in R$$

$$x(2x-3) \leq 0$$

$$\frac{6-x}{11-3x} \geq 0, \frac{5x-16}{11-3x} \leq 0, x \neq \frac{11}{3}, 0 \leq x \leq \frac{3}{2}$$

$$(x-6)(5x-16) \geq 0, x \in \left[0, \frac{3}{2}\right]$$

$$x \in \left[(-\infty, \frac{16}{5}) \cup (6, \infty)\right] \cap \left[0, \frac{3}{2}\right]$$

$$\text{Domain} = \left[0, \frac{3}{2}\right]$$

$$\alpha = 0, \beta = \frac{3}{2} \quad \alpha + 2\beta = 3$$

14. The area of the region inside the ellipse $x^2 + 4y^2 = 4$ and outside the region bounded by the curve $y = |x| - 1$ and $y = 1 - |x|$ is

- 1) $2(\pi - 1)$ 2) $2\pi - \frac{1}{2}$ 3) $3(\pi - 1)$ 4) $2\pi - 1$

Key : 1

Sol: Ellipse $\frac{x^2}{4} + \frac{y^2}{1} = 1$

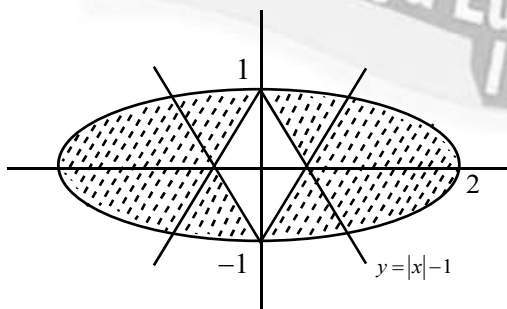

$$y = |x| - 1$$

$$y = 1 - |x|$$

$$\text{Required area} = \pi(2)(1) - \frac{1}{2}(2)(2) = 2\pi - 2 = 2(\pi - 1)$$

15. If the coefficient of x in the expansion of $(ax^2 + bx + c)(1 - 2x)^{26}$ is -56 and the coefficient of x^2 and x^3 are both zero then $a+b+c$ is equal to

- 1) 1483 2) 1500 3) 1300 4) 1403

Key : 4

Sol: $(ax^2 + bx + c)(1 - 2x)^{26}$

$$= (ax^2 + bx + c) [{}^{26}C_0 - {}^{26}C_1(2x) + {}^{26}C_2(2x)^2 - {}^{26}C_3(2x)^3]$$

$$b \cdot 1 + c \cdot (-{}^{26}C_1 \cdot 2) = -56$$

$$b - 52c = -56 \rightarrow (1)$$

$$a \cdot 1 + b \cdot ({}^{26}C_1 \cdot 2) + c \cdot {}^{26}C_2 \cdot (4) = 0$$

$$a - 52b + 1300c = 0 \rightarrow (2)$$

And $a \cdot (-{}^{26}C_1 \cdot 2) + b \cdot {}^{26}C_2 \cdot (4) + c \cdot (-{}^{26}C_3 \cdot 8) = 0$

$$-52a + 1300b - 20800c = 0 \rightarrow (3)$$

Solving (1), (2), (3); $a=1300$ $b=100$, $c=3$

$$a + b + c = 1403$$

16. Let PQ and MN be two straight lines touching the circle $x^2 + y^2 - 4x - 6y - 3 = 0$ at the point A and B respectively. Let O be centre of the circle and $\angle AOB = \frac{\pi}{3}$ then the locus of the point of intersection of the lines PQ and MN is

1) $x^2 + y^2 - 8x - 12y - 25 = 0$

2) $x^2 + y^2 - 12x - 18y - 25 = 0$

3) $3(x^2 + y^2) - 12x - 18y - 25 = 0$

4) $3(x^2 + y^2) - 18x - 12y + 25 = 0$

Key : 3

Sol: $x^2 + y^2 - 4x - 6y - 3 = 0$

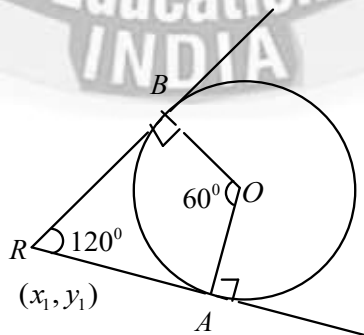

Center 'O' = (2,3)

$$\text{Radius } r = \sqrt{4+9+3} = 4$$

Let point of intersection of PQ and MN

be $R(x_1, y_1)$

$$\angle ARB = 120^\circ$$

$$\tan\left(\frac{120}{2}\right) = \frac{r}{\sqrt{S_{11}}}$$

$$\sqrt{3} = \frac{4}{\sqrt{S_{11}}}$$

$$3[x_1^2 + y_1^2 - 4x_1 - 6y_1 - 3] = 16$$

$$\text{Locus of R is } 3(x^2 + y^2) - 12x - 18y - 25 = 0$$

17. Let the mean and variance of 7 observations 2, 4, 10, x, 12, 14, y, $x > y$, be 8 and 16 respectively. Two numbers are chosen from $\{1, 2, 3, x-4, y, 5\}$ one after another without replacement. Then the probability that the smaller number among the two chosen numbers is less than 4 is

- 1) $\frac{4}{5}$ 2) $\frac{1}{3}$ 3) $\frac{3}{5}$ 4) $\frac{2}{5}$

Key : 1

Sol:
$$\frac{2+4+10+x+12+14+y}{7} = 8$$

$$42 + x + y = 56$$

$$x + y = 14 \rightarrow (1)$$

$$\sigma^2 = \frac{\sum x_i^2}{n} - \left(\frac{\sum x_i}{n}\right)^2$$

$$16 = \frac{4+16+100+x^2+144+196+y^2}{7} - 64$$

$$(80)(7) = x^2 + y^2 + 460$$

$$x^2 + y^2 = 560 - 460$$

$$x^2 + y^2 = 100. \rightarrow (2)$$

$$x = 8, y = 6$$

Given set $\{1, 2, 3, 4, 6, 5\}$

Let E be the event that both the numbers are greater or equal to 4

$$P(E) = \frac{{}^3C_2}{{}^6C_2} = \frac{3}{15} = \frac{1}{5}$$

Required probability $1 - \frac{1}{5} = \frac{4}{5}$

18. Let c and d be vectors such that $|c+d| = \sqrt{29}$ and $c \times (2i+3j+4k) = (2i+3j+4k) \times d$. If

$\lambda_1, \lambda_2 (\lambda_1 > \lambda_2)$ are the possible values of $(c+d) \cdot (-7i+2j+3k)$ then the equation

$K^2x^2 + (K^2 - 5K + \lambda_1)xy + (3K + \frac{\lambda_2}{2})y^2 - 8x + 12y + \lambda_2 = 0$ represents of a circle for K equal to

- 1) 4 2) 2 3) -1 4) 1

Key : 4

Sol: $|\bar{c} + \bar{d}| = \sqrt{29}$

Let $\bar{b} = 2\bar{i} + 3\bar{j} + 4\bar{k}$

$\bar{c} \times \bar{b} = \bar{b} \times \bar{d}$

$(\bar{c} \times \bar{b}) + (\bar{d} \times \bar{b}) = \bar{0}$

$(\bar{c} + \bar{d}) \times \bar{b} = \bar{0}$

$\bar{c} + \bar{d} = t\bar{b}$

$|\bar{c} + \bar{d}| = |t| \sqrt{4+9+16}$

$\sqrt{29} = |t| \sqrt{29}$

$t = \pm 1$

$\bar{c} + \bar{d} = \pm(2\bar{i} + 3\bar{j} + 4\bar{k})$

$(\bar{c} + \bar{d}) \cdot (-7\bar{i} + 2\bar{j} + 3\bar{k}) = \pm(-14 + 6 + 12) = \pm(4)$

$\lambda_1 = 4, \lambda_2 = -4$

$K^2x^2 + (K^2 - 5K + \lambda_1)xy + (3K + \frac{\lambda_2}{2})y^2 - 8x + 12y + \lambda_2 = 0$

Represents a circle $K^2 - 5K + 4 = 0 \Rightarrow K = 1, \text{ or } 4$

$K^2 = 3K - 2 \Rightarrow K^2 - 3K + 2 = 0 \Rightarrow K = 1 \text{ or } 2$

Hence $K = 1$

19. Let O be the vertex of the parabola $x^2 = 4y$ and Q be any point on it let the locus of the point P which divides

The line segment OQ internally in the ratio $2:3$ be the conic C then the equation of the chord of C which is bisected at point $(1,2)$ is

- 1) $5x - 4y + 3 = 0$ 2) $5x - y - 3 = 0$ 3) $4x - 5y + 6 = 0$ 4) $x - 2y + 3 = 0$

Key : 1

Sol: $x^2 = 4y$

Let $Q = (2t, t^2), P(h, k)$

$(h, k) = \left(\frac{2(2t)}{5}, \frac{2t^2}{5} \right)$

$h = \frac{4t}{5}, K = \frac{2t^2}{5}$

$$5K = 2\left(\frac{5h}{4}\right)^2$$

$$8K = 5h^2$$

Locus of P is $5x^2 = 8y$

Equation of chord having (1,2) as mid point is

$$S_1 = S_{11}$$

$$5x(1) - 4(y+2) = 5(1)^2 - 8(2)$$

$$5x - 4y - 8 = 5 - 16$$

$$5x - 4y + 3 = 0$$

20. Let (α, β, γ) be the co-ordinates of the foot of the perpendicular drawn from the point $(5, 4, 2)$ on the line $r = (-i + 3j + k) + \lambda(2i + 3j - k)$ then the length of the projection of vector $\alpha i + \beta j + \gamma k$ on the vector $6i + 2j + 3k$ is

1) $\frac{18}{7}$

2) $\frac{15}{7}$

3) 3

4) 4

Key : 1

Sol: Given line : $\frac{x+1}{2} = \frac{y-3}{3} = \frac{z-1}{-1}$ (L)

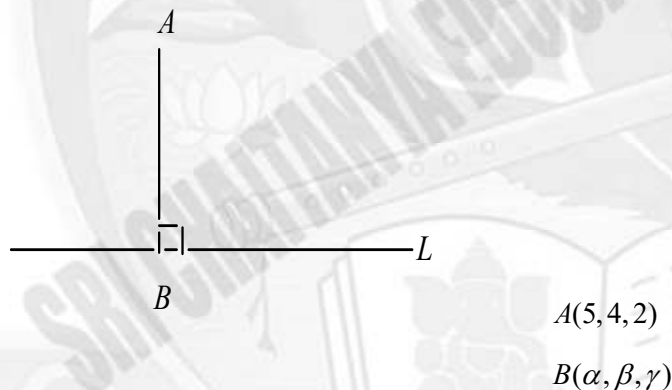

Let $B = (2\lambda - 1, 3\lambda + 3, -\lambda + 1)$

Drs of $\overline{AB} = (2\lambda - 6, 3\lambda - 1, -\lambda - 1)$

$AB \perp L$

$$2(2\lambda - 6) + 3(3\lambda - 1) - 1(-\lambda - 1) = 0$$

$$4\lambda - 12 + 9\lambda - 3 + \lambda + 1 = 0$$

$$14\lambda - 14 = 0$$

$$\lambda = 1$$

$$B = (1, 6, 0)$$

Let $\vec{a} = \alpha\vec{i} + \beta\vec{j} + \gamma\vec{k} = \vec{i} + 6\vec{j}$ and $\vec{b} = 6\vec{i} + 2\vec{j} + 3\vec{k}$

$$\vec{a} \cdot \vec{b} = 6 + 12 = 18$$

$$|\vec{b}| = \sqrt{36 + 4 + 9} = 7$$

$$\text{Projection of } \bar{a} \text{ on } \bar{b} = \frac{\bar{a} \cdot \bar{b}}{|\bar{b}|} = \frac{18}{7}$$

Section-II (NUMERICAL VALUE Type)

This section contains **5 Numerical Value Type Questions**. The Answer should be within **0 to 9999**. If the Answer is in **Decimal** then round off to the **Nearest Integer** value (Example i.e. If answer is above **10** and less than **10.5** round off is **10** and If answer is from **10.5** and less than **11** round off is **11**).

Marking scheme: +4 for correct answer, 0 if not attempt and -1 in all other cases.

21. Let $a_1 = 1$ and for $n \geq 1, a_{n+1} = \frac{1}{2}a_n + \frac{n^2 - 2n - 1}{n^2(n+1)^2}$ then $\left| \sum_{n=1}^{\infty} \left(a_n - \frac{2}{n^2} \right) \right|$ is equal to

Key : 2

$$\text{Sol: } a_{n+1} = \frac{1}{2}a_n + \frac{n^2 - 2n - 1}{n^2(n+1)^2} = \frac{1}{2}a_n + \frac{2n^2 - (n+1)^2}{n^2(n+1)^2}$$

$$a_{n+1} - \frac{2}{(n+1)^2} = \frac{1}{2}a_n - \frac{1}{n^2} = \frac{1}{2} \left[a_n - \frac{2}{n^2} \right]$$

$$\text{Let } b_n = a_n - \frac{2}{n^2}$$

$$b_{n+1} = \frac{1}{2}b_n$$

b_1, b_2, \dots, b_{n+1} are in GP

$$\text{With } r = \frac{1}{2}$$

$$b_1 = a_1 - \frac{2}{1} = 1 - 2 = -1$$

$$\text{Now } \left| \sum_{n=1}^{\infty} \left(a_n - \frac{2}{n^2} \right) \right| = \left| \sum_{n=1}^{\infty} b_n \right| = \left| \frac{-1}{1 - \frac{1}{2}} \right| = 2$$

22. $6 \int_0^{\pi} |(\sin 3x + \sin 2x + \sin x)| dx$ is equal to

Key : 17

$$\begin{aligned} \text{Sol: } & 6 \int_0^{\pi} |\sin 3x + \sin 2x + \sin x| dx \\ &= 6 \int_0^{\pi} |\sin 2x + 2 \sin 2x \cos x| dx = 6 \int_0^{\pi} |\sin 2x (1 + 2 \cos x)| dx \\ &= 6 \int_0^{\pi} |2 \cos x (1 + 2 \cos x)| \sin x dx \quad \cos x = t \\ &= 12 \int_1^{-1} |t(1 + 2t)| - dt \quad -\sin x dx = dt \end{aligned}$$

$$\begin{aligned}
 &= 12 \int_{-1}^1 |t(1+2t)| dt = 12 \left[\int_{-1}^{-1/2} (t+2t^2) dt - \int_{-1/2}^0 (t+2t^2) dt + \int_0^1 (t+2t^2) dt \right] \\
 &= 12 \left[\left(\frac{t^2}{2} + \frac{2t^3}{3} \right)_{-1}^{-1/2} - \left(\frac{t^2}{2} + \frac{2t^3}{3} \right)_{-1/2}^0 + \left(\frac{t^2}{2} + \frac{2t^3}{3} \right) \right] \\
 &= 12 \left[\left(\frac{1}{8} - \frac{1}{12} \right) - \left(\frac{1}{2} - \frac{2}{3} \right) + \left(\frac{1}{8} - \frac{1}{12} \right) + \left(\frac{1}{2} + \frac{2}{3} \right) \right] \\
 &= 12 \left[\frac{2}{8} - \frac{2}{12} + \frac{4}{3} \right] = 12 \left[\frac{1}{4} - \frac{1}{6} + \frac{4}{3} \right] = 3 - 2 + 16 = 17
 \end{aligned}$$

OR

$$6 \int_0^{\pi} |2 \sin 2x \cos x + \sin 2x| dx$$

$$6 \int_0^{\pi} |4 \sin x \cos^2 x + 2 \sin x \cos x| dx$$

$$I = 12 \int_0^{\pi} \sin x |2 \cos^2 x + \cos x| dx \quad \text{Put } \cos x = t, -\sin x dx = dt$$

23. For some $\alpha, \beta \in \mathbb{R}$ let $A = \begin{bmatrix} \alpha & 2 \\ 1 & 2 \end{bmatrix}$ and $B = \begin{bmatrix} 1 & 1 \\ 1 & \beta \end{bmatrix}$ be such that $A^2 - 4A + 2I = B^2 - 3B + I = 0$

then $(\det(\text{adj}(A^3 - B^3)))^2$ is equal to

Key : 225

Sol: $\text{tr}(A) = 4$

$$\alpha + 2 = 4$$

$$\alpha = 2$$

$$\text{tr}(B) = 3$$

$$1 + \beta = 3$$

$$\beta = 2$$

$$A^2 = \begin{pmatrix} 2 & 2 \\ 1 & 2 \end{pmatrix} \begin{pmatrix} 2 & 2 \\ 1 & 2 \end{pmatrix} = \begin{pmatrix} 6 & 8 \\ 4 & 6 \end{pmatrix}$$

$$A^3 = \begin{pmatrix} 2 & 2 \\ 1 & 2 \end{pmatrix} \begin{pmatrix} 6 & 8 \\ 4 & 6 \end{pmatrix} = \begin{pmatrix} 20 & 28 \\ 14 & 20 \end{pmatrix}$$

$$B^2 = \begin{bmatrix} 1 & 1 \\ 1 & 2 \end{bmatrix} \begin{bmatrix} 1 & 1 \\ 1 & 2 \end{bmatrix} = \begin{bmatrix} 2 & 3 \\ 3 & 5 \end{bmatrix}$$

$$B^3 = \begin{bmatrix} 1 & 1 \\ 1 & 2 \end{bmatrix} \begin{bmatrix} 2 & 3 \\ 3 & 5 \end{bmatrix} = \begin{bmatrix} 5 & 8 \\ 8 & 13 \end{bmatrix}$$

$$A^3 - B^3 = \begin{bmatrix} 15 & 20 \\ 6 & 7 \end{bmatrix}$$

$$|A^3 - B^3| = 105 - 120 = -15$$

$$|adj(A^3 - B^3)|^2 = (|A^3 - B^3|^{2-1})^2 = (-15)^2 = 225$$

24. Let $S = \{(m, n) : m, n \in (1, 2, 3, \dots, 50)\}$ if number of elements (m, n) in S such that $6^m + 9^n$ is a multiple of 5 is P and the number of elements (m, n) in S such that $m+n$ is a square of a prime number is Q then $P+Q$ is equal to

Key : 1333

Sol: $6^m = (5+1)^m = 5k + 1$

$$9^n = (10-1)^n = 10l - 1 \text{ if } n \text{ is odd}$$

$6^m + 9^n$ is divisible by 5

If m can be any of $\{1, 2, 3, \dots, 50\}$

And n is odd from $\{1, 2, 3, \dots, 50\}$

No. of ways = 50×25

$$P = 1250$$

$$m+n=4 \rightarrow \text{no. of ways} = 3$$

$$m+n=9 \rightarrow \text{no. of ways} = 8$$

$$m+n=25 \rightarrow \text{no. of ways} = 24$$

$$m+n=49 \rightarrow \text{no. of ways} = 48$$

$$Q = 3 + 8 + 24 + 48 = 83$$

$$\therefore P+Q = 1250 + 83 = 1333$$

25. Let $f: R \rightarrow R$ be a twice differentiable function such that the quadratic equation

$$f(x)m^2 - 2f'(x)m + f''(x) = 0$$

In m , has two equal roots for every $x \in R$. If $f(0) = 1$, $f'(0) = 2$, and (α, β) is the largest interval in which the functions $f(\log_e x - x)$ is increasing, then $\alpha + \beta$ is equal to

Key: 1

Sol: $f(x)m^2 - 2f'(x)m + f''(x) = 0$

$$\Delta = 0$$

$$[2f'(x)]^2 = 4f(x)f''(x)$$

$$\int \frac{f'(x)}{f(x)} dx = \int \frac{f''(x)}{f'(x)} dx$$

$$\ln f(x) = \ln f'(x) + \ln C$$

$$f(x) = Cf'(x)$$

$$f(0) = 1 \Rightarrow 1 = Cf'(0)$$

$$1 = C \cdot 2$$

$$C = \frac{1}{2}$$

$$\therefore 2f(x) = f'(x)$$

$$\frac{f'(x)}{f(x)} = 2$$

$$\int \frac{f'(x)}{f(x)} dx = \int 2 dx$$

$$\ln f(x) = 2x + K$$

$$x = 0 \Rightarrow 0 = 0 + K$$

$$K = 0$$

$$\therefore \ln f(x) = 2x$$

$$f(x) = e^{2x}$$

$$\text{Let } g(x) = f[\ln x - x]$$

$$g(x) = e^{2(\ln x - x)}$$

$$g'(x) = e^{2(\ln x - x)} \left[\frac{1}{x} - 1 \right]$$

$g(x)$ is increasing

$$g'(x) > 0$$

$$\frac{1}{x} - 1 > 0$$

$$\frac{1}{x} > 1$$

$$0 < x < 1$$

$$x \in (0, 1)$$

$$\alpha = 0, \beta = 1 \quad \alpha + \beta = 1$$

PHYSICS

Max Marks: 100

Section-I
(SINGLE CORRECT ANSWER TYPE)

This section contains **20 Multiple Choice Questions**. Each question has 4 options (1), (2), (3) and (4) for its answer, out of which ONLY ONE option can be correct.

Marking scheme: +4 for correct answer, 0 if not attempted and -1 in all other cases.

26. A gas based geyser heated water flowing at the rate of 5.0 litres per minute from $27^{\circ}C$ to $87^{\circ}C$. The rate of consumption of the gas is ___ g/s.

(Take heat of combustion of gas = $5.0 \times 10^4 J/g$, specific heat capacity of water = 4200 J/kg. $^{\circ}C$)

- 1) 2.1 2) 0.21 3) 4.2 4) 0.42

Key: 4

Sol: $\dot{m}_w C_w \Delta T = \dot{m}_g C_g$

$$\frac{(5 \times 10^{-3} \times 10^3) \times 4200}{60} \times (87 - 27) = \dot{m}_g \times 5 \times 10^4 \Rightarrow \dot{m}_g = 0.42$$

27. The point of charge of $10^{-8}C$ is placed at origin. The work done in moving a point at $2 \mu C$ from point A(4,4,2) m to B(2,2,1) m is _____ J. ($\frac{1}{4\pi \epsilon_0} = 9 \times 10^9$ in SI unit)

- 1) 45×10^{-6} 2) 30×10^{-6} 3) 15×10^{-6} 4) 0

Key: 2

Sol: $W = \Delta U = Kq_1q_2 \left(\frac{1}{r_2} - \frac{1}{r_1} \right) = (9 \times 10^9) \times (10^{-8}) \times (9 \times 10^{-6}) \times \left(\frac{1}{3} - \frac{1}{6} \right) = 30 \times 10^{-6}$

28. A light wave described by $E = 60 \left[\sin(3 \times 10^{15})t + \sin(12 \times 10^{15})t \right]$ (in SI units) fall on a metal surface of work function 2.8 eV. The maximum kinetic energy of ejected photoelectron is (approximately) ___ eV. ($h = 6.6 \times 10^{-34} J.s.$ and $e = 1.6 \times 10^{-19} C$)

- 1) 3.8 2) 6.0 3) 7.8 4) 5.1

Key: 4

Sol: $w = 12 \times 10^{15}$ $E_{photon} = h\gamma = \frac{hw}{2\pi} = 7.88 eV$

$$kE = E_{ph} - \phi = 7.88 - 2.8 = 5.08$$

29. A uniform rod of mass m and length l suspended by means of two identical inextensible light strings as shown in figure. Tension in one string immediately after the other string is cut is _____. (g – acceleration due to gravity)

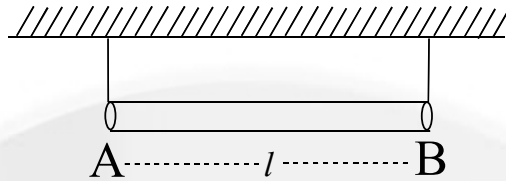

- 1) $mg/2$ 2) mg 3) $mg/3$ 4) $mg/4$

Key: 4

Sol:

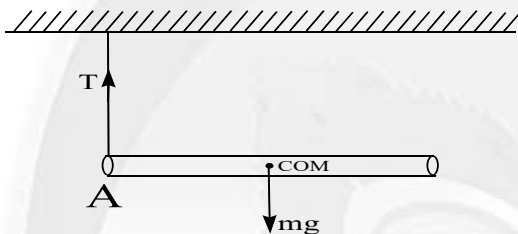

$$F_{NET} = ma \Rightarrow mg - T = ma$$

$$\tau_{COM} = I\alpha \Rightarrow T \frac{l}{2} = \frac{ml^2}{12} \times \alpha \Rightarrow T = \frac{ml\alpha}{6}$$

$$\text{Constraint at A} \Rightarrow (a_A)_y = 0 \Rightarrow \frac{\alpha l}{2} = a$$

$$\text{On solving } T = \frac{mg}{4}$$

30. A 4Kg mass moves under the influence of a force $F = (4t^3 i - 3t j) N$ where t is time in sec. If mass starts from origin $a + t = 0$, the velocity and position after $t=2s$ will be

- 1) $v = 4i - \frac{3}{2}j$; $r = \frac{6}{5}i - j$ 2) $v = 4i - \frac{3}{2}j$; $r = \frac{8}{5}i - j$
 3) $v = 4i + \frac{5}{2}j$; $r = \frac{8}{5}i + 2j$ 4) $v = 3i + \frac{3}{2}j$; $r = \frac{6}{5}i + j$

Key: 2

$$\text{Sol: } F_x = ma_x \Rightarrow F_x = m \left(\frac{dV_x}{dt} \right) \Rightarrow 4t^3 = 4 \left(\frac{dV_x}{dt} \right) \Rightarrow \int_0^2 t^3 dt = \int_0^{V_x} dV_x \Rightarrow V_x = 4$$

$$\text{For position: } 4t^3 = 4 \left(\frac{dV_x}{dt} \right) \Rightarrow \int dV_x = \int t^3 dt \Rightarrow V_x = \frac{t^4}{4}$$

$$\frac{dx}{dt} = \frac{t^4}{4} \Rightarrow \int_0^x dx = \frac{1}{4} \left(\int_0^t t^4 dt \right) = \frac{1}{4} \left(\frac{t^5}{5} \right) \Rightarrow x = \frac{8}{5}$$

$$F_y = ma_y \Rightarrow F_y = m \left(\frac{dV_y}{dt} \right) \Rightarrow \int_0^2 (-3t) dt = 4 \int_0^{V_y} dV_x \Rightarrow V_y = \frac{-3}{2}$$

31. The given circuit works as:

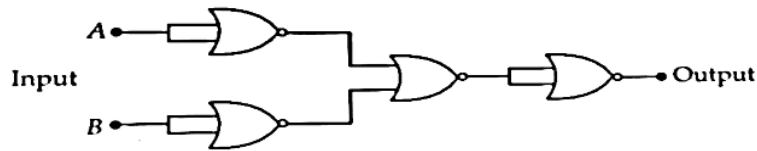

- 1) AND gate 2) NOR gate 3) NAND gate 4) OR gate

Key: 3

Sol: NAND

32. A 1 m long metal rod AB completes the circuit as shown in figure. The area of circuit is perpendicular to the magnetic field of 0.10 T. If the resistance of the total circuit is 2Ω then the force needed to move the rod towards right with constant speed (v) of 1.5 m/s is _____ N.

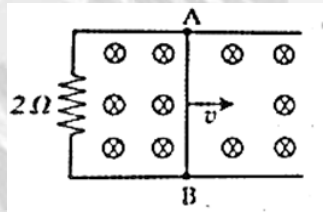

- 1) 5.7×10^{-3} 2) 7.5×10^{-3} 3) 7.5×10^{-2} 4) 5.7×10^{-2}

Key: 2

Sol:
$$F = \frac{B^2 l^2 v}{R} = \frac{(0.1)^2 \times 1^2 \times 1.5}{2} = \frac{3}{400} = 7.5 \times 10^{-3}$$

33. A conducting circular loop of area 1.0 m^2 is placed perpendicular to a magnetic field which varies as $B = \sin(100t)$ Tesla. If the resistance of the loop is 100Ω , Then the average thermal energy dissipated in the loop in one period is _____ J.

- 1) 2π 2) π 3) π^2 4) $\pi/2$

Key: 2

Sol:
$$E = -\frac{d\phi}{dt} = -A \times \frac{dB}{dt} = -A \times (-\cos(100t)) \times 100 = 100A \cos(100t)$$

$$\text{Heat} = \int_0^T \left(\frac{E^2}{R} \right) dt = \int_0^T \cos^2(100t) dt = \pi$$

34. A current carrying solenoid is placed vertically and a particle of mass m which charge Q is released from rest. The particle move along the axis of solenoid. If g is acceleration due to gravity, then the acceleration (a) of the charged particle will satisfy

- 1) $a=g$ 2) $a=0$ 3) $0<a<g$ 4) $a>g$

Key: 1

Sol: Magnetic Force=0

Net force = gravity

Acceleration = g

35. In a double slit experiment, the distance between the slits is 0.1cm and the screen is placed at 50cm from the slit plan. When one slit is covered with a transparent sheet having thickness t and refractive index $n(=1.5)$, the central fringe shifts by 0.2cm. The value of t is

- 1) 5.6×10^{-4} 2) 5.0×10^{-3} 3) 8×10^{-4} 4) 6.0×10^{-3}

Key: 3

Sol: Shift $x = \frac{Dt(\mu - v)}{d} \Rightarrow 0.2 = \frac{50 \times t \times 0.5}{0.1} \Rightarrow t = 8 \times 10^{-4} \text{ cm}$

36. If an alpha particle with energy 7.7 MeV is bombarded on a thin gold foil, the closest distance from nucleus it can reach is _____m. (Atomic number of gold = 79 and

$\frac{1}{4\pi\epsilon_0} = 9 \times 10^9$ in SI units)

- 1) 2.95×10^{-14} 2) 2.95×10^{-16} 3) 3.85×10^{-14} 4) 3.85×10^{-16}

Key: 1

Sol: Conservation of mechanical energy

$$\Delta v = -\Delta K$$

$$\frac{kzq_1q_2}{r} = -\left[0 - \frac{m}{2}v^2\right] \left(\begin{array}{l} \text{where } q_1 = Ze \\ q_2 = Ze \end{array}\right)$$

$$\frac{9 \times 10^9 \times 79 \times (1.6 \times 10^{-19})^2 \times 2}{r} = 7.7 \times 10^6 \times 1.6 \times 10^{-19}$$

$$r = \frac{9 \times 10^9 \times 79 \times 1.6 \times 10^{-19} \times 2}{7.7 \times 10^6} = 147.7 \times 10^{-16} \times 2$$

$$= 295.48 \times 10^{-16} = 2.99548 \times 10^{-14}$$

37. Potential energy (V) versus distance (x) is given by the graph. Rank various regions as per the magnitudes of the force (F) acting on a particle from high to low.

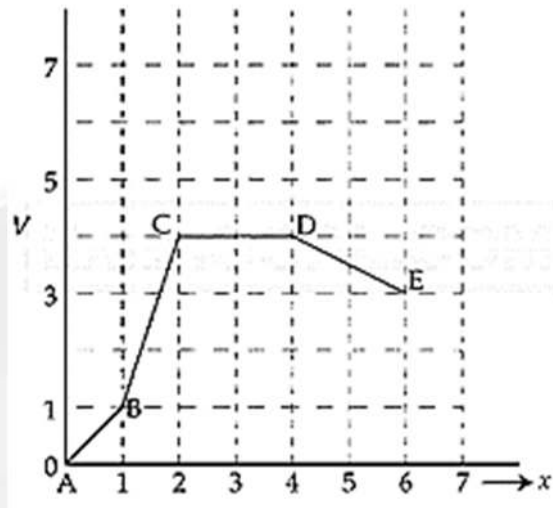

- 1) $F_{CD} > F_{AB} > F_{BC} > F_{DE}$ 2) $F_{CD} > F_{DE} > F_{AB} > F_{BC}$
 3) $F_{BC} > F_{CD} > F_{DE} > F_{AB}$ 4) $F_{BC} > F_{AB} > F_{DE} > F_{CD}$

Key: 4

Sol: $F = -\frac{du}{dx}$

$F \propto \text{slope}$

38. Two strings (A,B) having linear densities $\mu_A = 2 \times 10^{-4} \text{ kg/m}$ and $\mu_B = 4 \times 10^{-4} \text{ kg/m}$ and lengths $L_A = 2.5 \text{ m}$ and $L_B = 1.5 \text{ m}$ respectively are joined. Free ends of A and B are tied to two rigid supports C and D, respectively creating a tension of 500 N in the wire. Two identical pulses, sent from C and D ends, take time t_1 and t_2 respectively, to reach the joint. The ratio t_1/t_2 is :

- 1) 1.90 2) 1.67 3) 1.18 4) 1.08

Key: 3

Sol:
$$\frac{t_1}{t_2} = \frac{\frac{l_1}{v_1}}{\frac{l_2}{v_2}} = \frac{\frac{2.5}{\sqrt{T/\mu_A}}}{\frac{1.5}{\sqrt{T/\mu_B}}} = \frac{25}{15} \times \sqrt{\frac{\mu_A}{\mu_B}} = \frac{5}{3} \times \sqrt{\frac{2}{4}}$$

$$\frac{5}{3\sqrt{2}} = 1.17$$

39. Consider a modified Bernoulli equation. $\left(P + \frac{A}{Bt^2}\right) + \rho g(h + Bt) + \frac{1}{2}\rho V^2 = \text{Constant}$

If f has the dimension of time then the dimension A and B are _____, _____ respectively.

- 1) $[ML^0T^{-2}]$ and $[M^0LT^{-1}]$ 2) $[ML^0T^{-1}]$ and $[M^0LT^{-1}]$
 3) $[ML^0T^{-2}]$ and $[M^0LT^{-2}]$ 4) $[ML^0T^{-1}]$ and $[M^0LT]$

Key:2

Sol: $[h] = [Bt] \Rightarrow [B] = \left[\frac{h}{t}\right] = [LT^{-1}]$

$$[P] = \left[\frac{A}{Bt^2}\right] \Rightarrow [A] = [P][B][t^2] = [ML^{-1}T^{-2}][LT^{-1}][T^2] = [MT^{-1}]$$

40. Initially a satellite of 100 kg is in a circular orbit of radius $1.5R_E$. This satellite can be moved to a circular orbit of radius $3R_E$ by supplying $\alpha \times 10^6 J$ of energy. The value of α is _____ (Take Radius of Earth $R_E = 6 \times 10^6$ m and $g = 10 m/s^2$)

- 1) 100 2) 150 3) 1000 4) 500

Key: 3

Sol: $w = \Delta \text{ Mechanical energy} = \Delta KE + \Delta PE = \frac{m}{2}(v_f^2 - v_i^2) + \left(\frac{-GMm}{r_f} + \frac{GMm}{r_i}\right)$

$$\left[V = \sqrt{\frac{GM}{r}}\right] = \frac{m}{2} \left(\frac{GM}{3R} - \frac{GM}{\frac{3}{2}R}\right) + \frac{GMm}{R} \left(-\frac{1}{3} + \frac{1}{\frac{3}{2}}\right) = \frac{-GMm}{6R} + \frac{1}{3} \frac{GMm}{R} = \frac{GMm}{6R} \times \frac{R}{R}$$

$$\left(\text{put } g = \frac{GM}{R^2}\right) = \frac{gmR}{6} = \frac{10 \times 100 \times 6 \times 10^6}{6} = 10^9$$

41. Water flows through a horizontal tube as shown in the figure. The difference in height between the water

Columns in vertical tubes is 5 cm and the area of cross-sections at A and B are 6 cm^2 and 3 cm^2 respectively. The rate of flow will be _____ cm^3 / s . (take $g = 10 \text{ m/s}^2$)

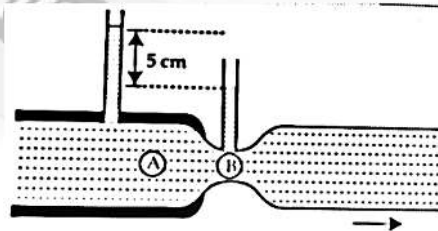

- 1) $200\sqrt{3}$ 2) $\frac{200}{\sqrt{3}}$ 3) $100\sqrt{3}$ 4) $200\sqrt{6}$

Key: 1

$$\text{Sol: } Q = \frac{a_1 a_2}{\sqrt{a_1^2 - a_2^2}} \sqrt{2gH} = \frac{6 \times 3 \times (10^{-2})^2}{\sqrt{27}} \times \sqrt{2 \times 10 \times \frac{5}{100}} = \frac{6}{\sqrt{3}} \times 10^{-4} \times 1 = \frac{6}{\sqrt{3}} \times 10^{-4} \frac{m^3}{s} = \frac{600}{\sqrt{3}} \frac{cm^3}{s} = 200\sqrt{3} \frac{cm^3}{s}$$

42. The electric field in a plane electromagnetic wave is given by:

$$E_y = 69 \sin[0.6 \times 10^3 x - 1.8 \times 10^{11} t] \text{ V/m}$$

The expansion for magnetic field associated with this electromagnetic wave is ____ T.

- 1) $B_z = 2.3 \times 10^{-7} \sin[0.6 \times 10^3 x + 1.8 \times 10^{11} t]$ 2) $B_z = 2.3 \times 10^{-7} \sin[0.6 \times 10^3 x - 1.8 \times 10^{11} t]$
 3) $B_y = 69 \sin[0.6 \times 10^3 x + 1.8 \times 10^{11} t]$ 4) $B_y = 2.3 \times 10^{-7} \sin[0.6 \times 10^3 x - 1.8 \times 10^{11} t]$

Key: 2

Sol: Trigonometric function should be exactly same

Wave propagation $\rightarrow +ve$ x axis

$$E \times B \rightarrow +i$$

43. A parallel plate capacitor has capacitance C, when there is vacuum within the parallel

plates. A sheet having thickness $\left(\frac{1}{3}\right)^{rd}$ of the separation between the plates and relative permittivity K is introduced between the plates. The new capacitance of the system is :

- 1) $\frac{3KC}{2K+1}$ 2) $\frac{4KC}{3K-1}$ 3) $\frac{CK}{2+K}$ 4) $\frac{3CK^2}{(2K+1)^2}$

Key: 1

$$\text{Sol: } C^1 = \frac{A\epsilon_0}{d - t\left(1 - \frac{1}{k}\right)} = \frac{A\epsilon_0}{d\left(1 - \frac{t}{d}\left(1 - \frac{1}{k}\right)\right)} = \frac{C}{1 - \frac{1}{3}\left(1 - \frac{1}{k}\right)} = \frac{3CK}{2K+1}$$

44. In an experiment the values of two spring constants were measured as $k_1 = (10 \pm 0.2) \text{ N/m}$ and $k_2 = (20 \pm 0.3) \text{ N/m}$. If these spring are connected in parallel, then the percentage error in equivalent spring constant is :

- 1) 1.67% 2) 1.33% 3) 2.67% 4) 2.33%

Key: 1

$$\text{Sol: } K = k_1 + k_2 = 10 + 20 = 30$$

$$\Delta k = \Delta k_1 + \Delta k_2 = 0.2 + 0.3 = 0.5$$

$$\% = \frac{0.5}{30} \times 100 = 1.67$$

45. An aluminium and steel rods having same lengths and cross-sections are joined to make total length of 120 cm at 30°C . The coefficient of linear expansion of aluminium and steel are $24 \times 10^{-6} / ^\circ\text{C}$ and $1.2 \times 10^{-5} / ^\circ\text{C}$, respectively. The length of this composite rod when its temperature is raised to 100°C , is _____ cm

- 1) 120.03 2) 120.20 3) 120.06 4) 120.15

Key: 4

$$\text{Sol: } l_f = 120 + \Delta l_{Al} + \Delta l_{steel} = 120 + 60 \times 24 \times 10^{-6} \times 70 + 60 \times 1.2 \times 10^{-5} \times 70 = 120.1512$$

Section-II
(NUMERICAL VALUE Type)

This section contains **5 Numerical Value Type Questions**. The Answer should be within **0 to 9999**. If the Answer is in **Decimal** then round off to the **Nearest Integer** value (Example I.e. If answer is above **10** and less than **10.5** round off is **10** and If answer is from **10.5** and less than **11** round off is **11**).

Marking scheme: +4 for correct answer, 0 if not attempt and -1 in all other cases

46. In a microscope, the objective is having focal length $f_o = 2\text{cm}$ and eye-piece is having focal length $f_e = 4\text{cm}$. The tube length is 32cm. The magnification produced by this microscope for normal adjustment is _____.

Key: 100

$$\text{Sol: Magnification} = \frac{LD}{f_o f_e} = \frac{32 \times 25}{2 \times 4} = 100$$

47. A collimated beam of light diameter 2mm is propagating along x-axis. The beam is required to be expanded in a collimated beam of diameter 14 mm using a system of two convex lenses. If first lens has focal length 40 mm, then the focal length of second lens is _____ mm.

Key: 280

$$\text{Sol: } m = \frac{f_2}{f_1} = \frac{D_2}{D_1} \Rightarrow f_2 = f_1 \left(\frac{D_2}{D_1} \right) = 40 \times \frac{14}{2} = 280$$

48. A 10 mole of oxygen is heated at constant volume from 30°C to 40°C . The change in the internal energy of gas is _____ Cal. (The molar specific heat of oxygen at constant pressure. $C_p = 7\text{Cal} / \text{mol}^\circ\text{C}$ and $R = 2\text{Cal} / \text{mol}^\circ\text{C}$)

Key: 500

$$\text{Sol: } C_p - C_v = R \Rightarrow 7 - C_v = 2 \Rightarrow C_v = 5$$

$$\Delta U = nC_v \Delta T = 10 \times 5 \times 10 = 500$$

49. Two identical thin rods of mass M kg and length L m are connected as shown in figure. Moment of inertia of the combined rod system about an axis passing through point P and perpendicular to the plane of the rods is $\frac{x}{12} ML^2 \text{kg m}^2$. The value of x is _____

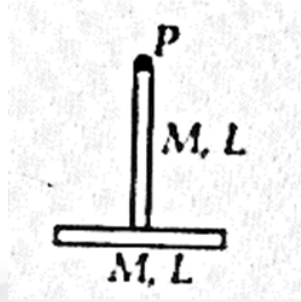

Key: 17

Sol: $\frac{ML^2}{3} + \frac{ML^2}{12} + ML^2 = \frac{17}{12} ML^2$

- 50.** The heat generated in 1 minute between points A and B in the given circuit, when a battery of 9 V with internal resistance of 1Ω is connected across these points is _____ J.

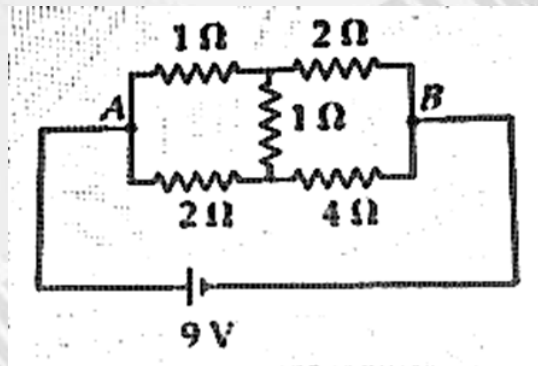

Key: 1080

Sol: Wheat stone bridge

$$R_{eff} = \frac{3 \times 6}{3+6} = 2 \text{ (Between A \& B)}$$

$$\therefore R_{total} = 2+1=3$$

$$i = \frac{V}{R_{total}} = \frac{9}{2+1} = 3$$

$$\text{Heat} = i^2 R t = 3^2 \times 2 \times 60 = 1080$$

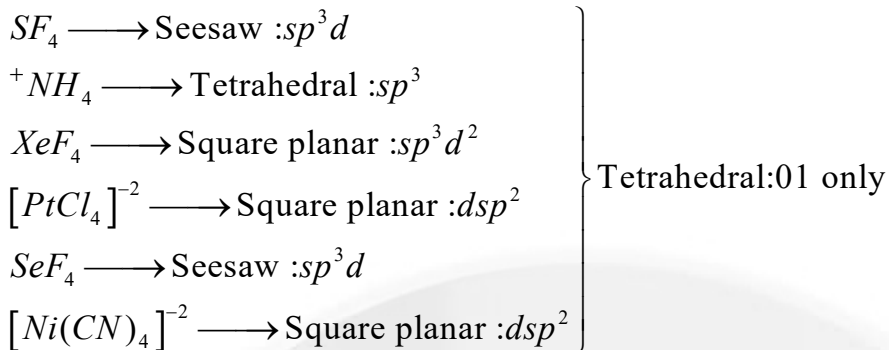

Statement-II is correct.

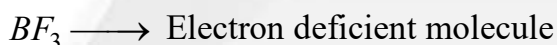

All the molecules have incomplete octet.

54. Identify correct statements:

A: Arginine and Tryptonphan, are essential Amino acid.

B: Histidine does not contain heterocyclic ring in its structure.

C: Proline is a six membered ring cyclic amino acid.

D: Glyncine does not have chiral center.

E: Cysteine has characteristic feature of side chain as $MeS - CH_2 - CH_2 -$.

Choose the correct answer from the options given below:

1) A and D only 2) B and E only 3) C and E only 4) C and D only

Key: 1

Sol: A and D are correct.

55. For the reaction $N_2O_4 \rightleftharpoons 2NO_2$, graph is plotted as shown below.

Identify correct statements.

A. Standard free energy change for the reaction is $-5.40kJmol^{-1}$.

B. As $\Delta G^{(-)}$ in graph is positive. N_2O_4 Will not dissociate into NO_2 at all.

C. Reverse reaction will go to completion.

D. When 1 mole of N_2O_4 changes into equilibrium mixture, value of

$$\Delta G^{(-)} = -0.84kJmol^{-1}.$$

E. When 2 mole of NO_2 changes into equilibrium mixture, $\Delta G^{(-)}$ for equilibrium mixture is $-6.24kJmol^{-1}$.

Sol:

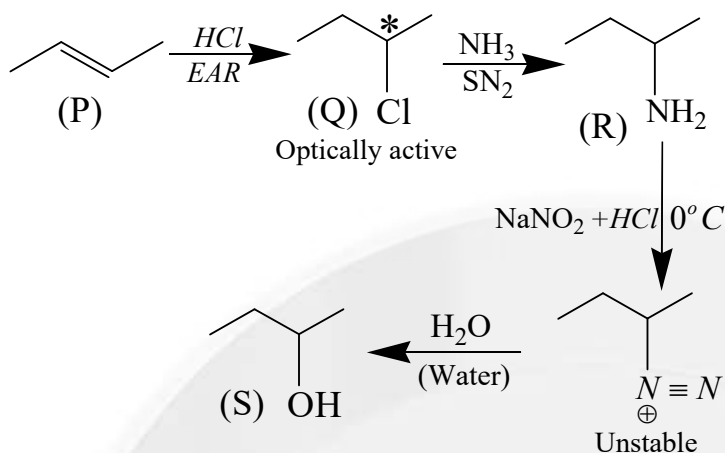

57. An organic compound (P) on treatment with aqueous ammonia under hot condition forms (Q) which on heating with Br_2 and KOH forms compound (R) having molecular formula $\text{C}_6\text{H}_7\text{N}$. Names of P, Q and R respectively are

- 1) Benzoic acid, benzamide, aniline
- 2) Toluic acid, methylbenzamide, 2-methylaniline
- 3) Benzoic acid, 4-methylbenzamide, 4-methylaniline
- 4) Phenylethanoic acid, phenylethanamide, benzamine

Key: 1

Sol:

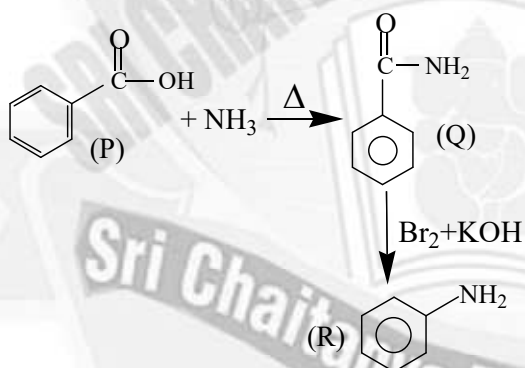

58. From the following the least stable structure is

- 1)
- 2)
- 3)
- 4)

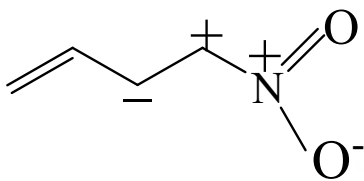
Key: 3**Sol:** unstable resonating structure is

59. An organic compound 'P' of molecular formula $C_6H_{12}O_3$ gives positive iodoform test but negative Tollen's test. When 'P' is treated with dilute acid, it produces 'Q'. 'Q' gives positive Tollen's test and also iodoform test. The structure of 'P' is

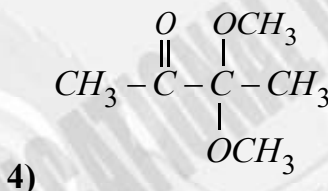
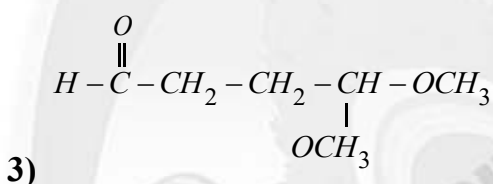
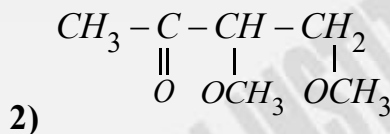
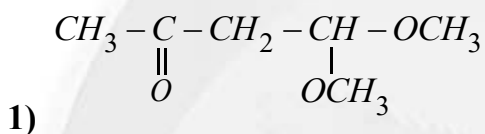
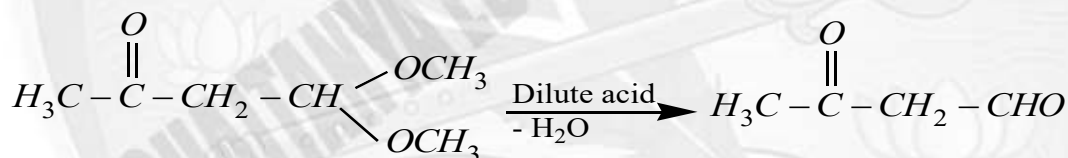
**Key: 1****Sol:**

60. Given below are two statements:

Statement-I: Among $[Cu(NH_3)_4]^{2+}$, $[Ni(en)_3]^{2+}$, $[Ni(NH_3)_6]^{2+}$ and $[Mn(H_2O)_6]^{2+}$,

$[Mn(H_2O)_6]^{2+}$ has the maximum number of unpaired electrons.

Statement-II: The number of pairs among $\{[NiCl_4]^{2-}, [Ni(CO)_4]\}$, $\{[NiCl_4]^{2-}, [Ni(CN)_4]^{2-}\}$

and $\{[Ni(CO)_4], [Ni(CN)_4]^{2-}\}$ that contain only diamagnetic species is two.

In the light of the above statements, those the correct answer from the given below:

- 1) Statement I is false, statement II is true
- 2) Both statement I and statement II are false
- 3) Statement I is true but statement II is false
- 4) Both statement I and statement II are true

Key: 3

Sol: Statement-I:

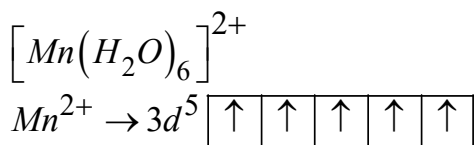

5 unpair electrons

Statement-II:

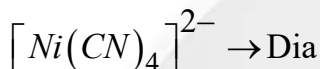
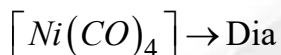
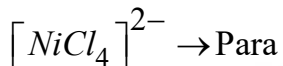

61. Which of the following represents the correct trend for the mentioned property?

A: $F > P > S > B$ – First Ionisation Energy.

B: $Cl > F > S > P$ – Electron Affinity.

C: $K > Al > Mg > B$ – Metallic Character.

D: $K_2O > Na_2O > MgO > Al_2O_3$ - Basic character.

Choose the correct answer from the options given below:

1) A, B and D only

2) A and B only

3) B and C only

4) A, B, C and D

Key: 1

Sol: A, B, D are correct.

C is incorrect. $K > Mg > Al > B$ is correct order.

62. 80mL of a hydrocarbon on mixing with 264ml of oxygen in a closed U-tube undergoes complete combustion. The residual gases after cooling to 273K occupy 224mL. When the system is treated with KOH solution, the volume decreases to 64mL. The formula of the hydrocarbon is

1) C_2H_4

2) C_2H_6

3) C_2H_2

4) C_4H_{10}

Key: 3

Sol:

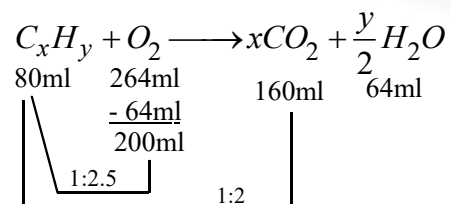

Hence the empirical formula = C_2H_2

63. Given below are two statements:

Statement – I: The number of pairs among $[SiO_2, CO_2]$, $[SnO, SnO_2]$, $[PbO, PbO_2]$ and $[GeO, GeO_2]$ which contains oxides that are both amphoteric is 2.

Statement – II: BF_3 is an electron deficient molecule, act as a Lewis acid forms adduct with NH_3 and has a trigonal planar geometry.

In the light of the above statements, Choose the correct answer from the options given below:

- 1) Both statements I and Statement II are true
- 2) Both statements I and Statement II are false
- 3) Statement I is false but statement II is true
- 4) Statement I is true but statement II is false

Key: 1

Sol: Statement-1: $[SnO; SnO_2]$ and $[PbO; PbO_2]$ are amphoteric.

Statement-1: BF_3 from adduct with NH_3 , which has trigonal planar geometry.

64. Elements 'P' and 'Q' form two types of non-volatile; non-ionizable compounds PQ and PQ_2 . When 1g of PQ is dissolved in 50g of solvent 'A'; ΔT_b was 1.176 K while when 1g of PQ_2 is dissolved in 50g of solvent 'A'; ΔT_b was 0.689K. (K_b of A is 5 K kg mol⁻¹).

The molar masses of element P and Q (in g mol⁻¹) respectively are

- 1) 70, 110
- 2) 25, 60
- 3) 65, 145
- 4) 60, 25

Key: 2

Sol: i) $M_{PQ} = \frac{K_b \times a \times 100}{\Delta T_b \times b} = \frac{5 \times 1 \times 100}{50 \times 1.176} = 85$ ii) $M_{PQ_2} = \frac{5 \times 1 \times 100}{50 \times 0.689} = 145$

We get, $P + Q = 85$ & $P + 2Q = 145$

On solving $P = 25$, $Q = 60$

65. Identify correct statements from the following :

- A) Propanal and propanone are functional isomers
- B) Ethoxyethane and methoxy propane are metamers
- C) But-2-ene shows optical isomerism
- D) But-1-ene and But-2-ene are functional isomers
- E) Pentane and 2,2-dimethyl propane are chain isomers

Choose the correct answer from the options given below:

- 1) A, B and E only
- 2) C, D and E only
- 3) B, C and D only
- 4) A, B and C only

Key: 1

Sol: A: Propanal & propanone is FGI.

B: $CH_3 - CH_2 - O - CH_2 - CH_3$; $CH_3 - O - CH_2 - CH_2 - CH_3$: metamers.

C:

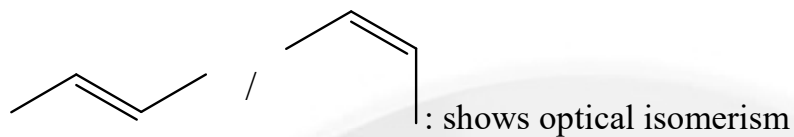

D:



66. Identify 'A' in the following reaction:

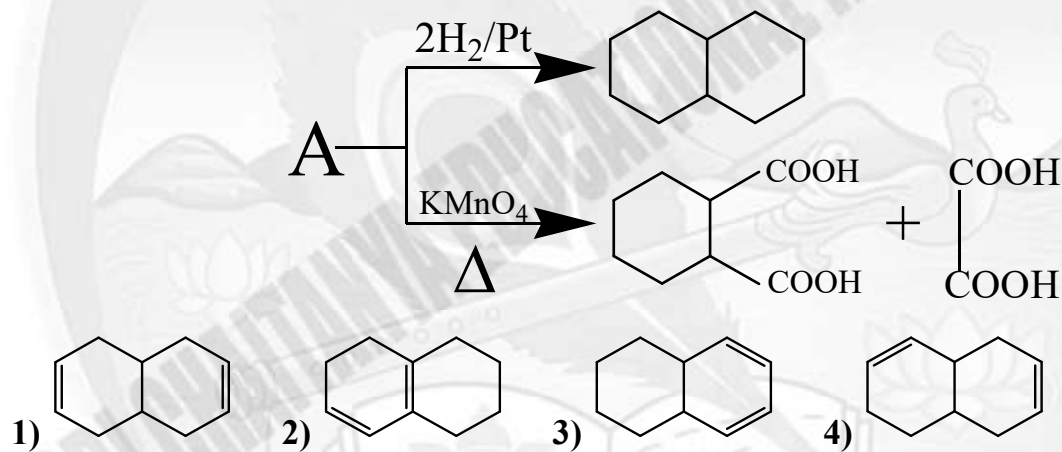

Key: 3

Sol:

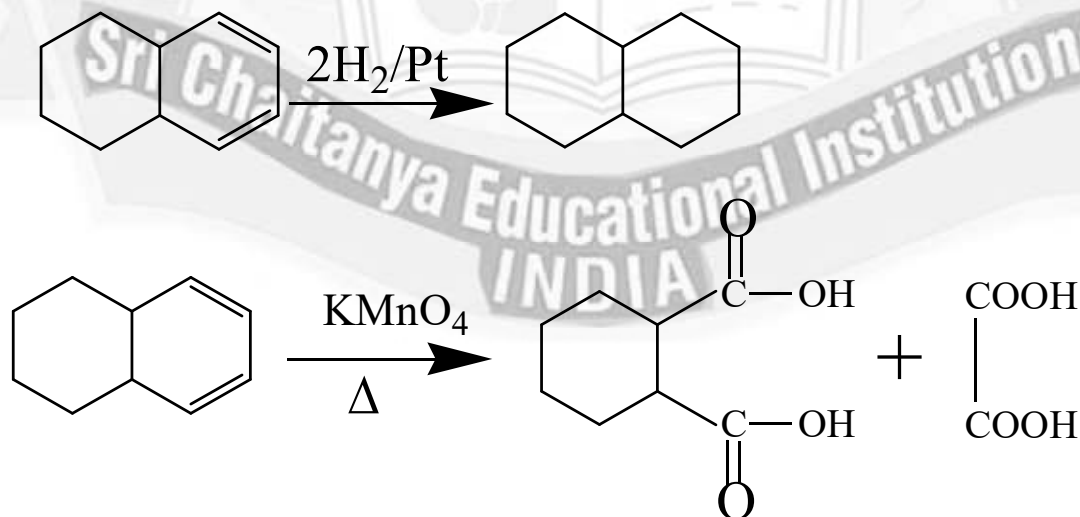

67. Which of the following graphs pressure 'P' versus volume 'V' represents the maximum workdone?

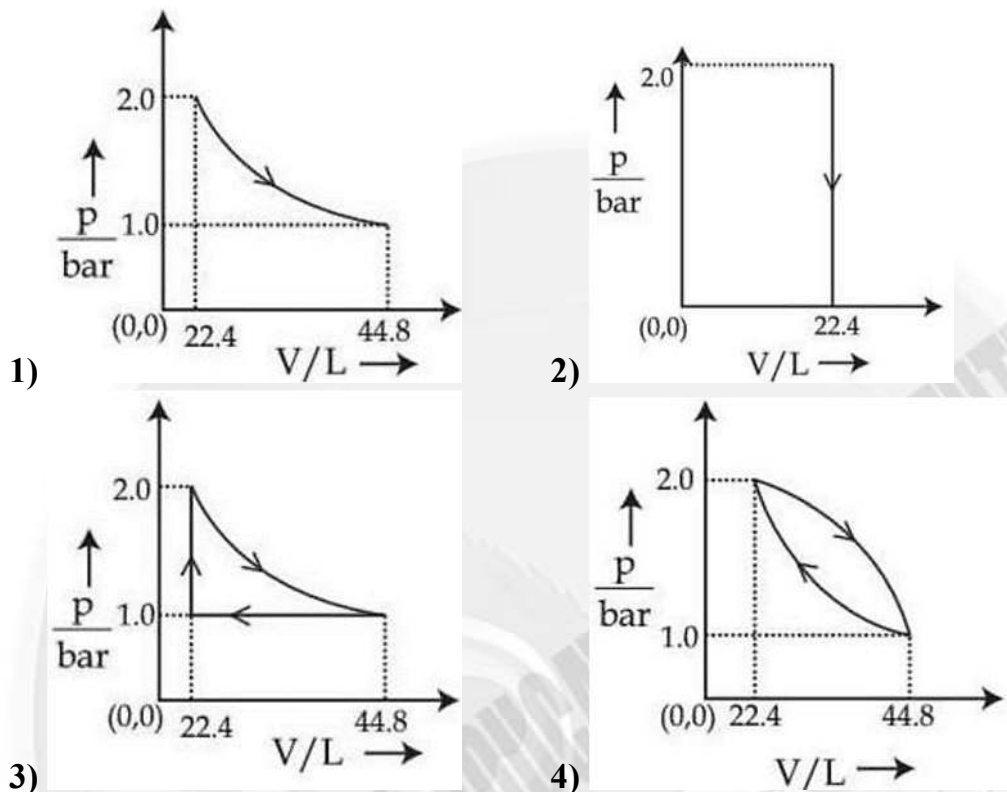

Key: 1

Sol: In graph 1, work done is positive, the area under this curve is largest.

68. **Statement – I:** When an electric discharge is passed through gaseous hydrogen, the hydrogen molecules dissociate and the energetically excited hydrogen atoms produce electromagnetic radiation of discrete frequencies.

Statement – II: The frequency of second line Balmer series obtained from He^+ equal to that of first line of Lyman series obtained from hydrogen atom.

In the light of the above statements, Choose the correct answer from the options given below:

- 1) Both statement I and statement II are false
- 2) Both statement I and statement II are true
- 3) Statement I is true but statement II is false
- 4) Statement I is false but statement II is true

Key: 2

Sol: 1st line of Hydrogen atom in Lyman series,

Second line of He^+ ion in Balmer series,

Third line of Li^{+2} ion in Paschen series

Above are having same frequency.

69. Consider the following reactions.

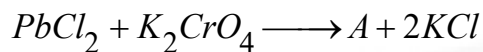

(Hot solution)

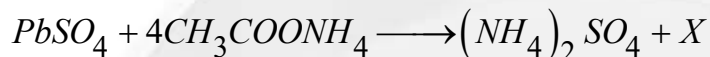

In the above reactions, A, B and X are respectively.

- 1) $PbCrO_4, Na_2[Pb(OH)_4]$ and $[Pb(NH_3)_4]SO_4$
- 2) $Na_2[Pb(OH)_4], PbCrO_4$ and $[Pb(NH_3)_4]SO_4$
- 3) $PbCrO_4, Na_2[Pb(OH)_4]$ and $(NH_4)_2[Pb(CH_3COO)_4]$
- 4) $Na_2[Pb(OH)_4], PbCrO_4$ and $(NH_4)_2[Pb(CH_3COO)_4]$ d

Key: 3

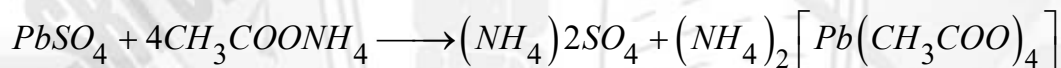
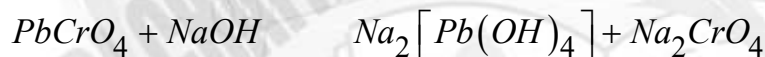
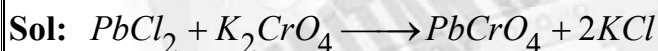

70. 14.0gm of calcium metal is allowed to react with excess HCl at 1.0 atm pressure and 273K which of the following statements is incorrect?

[Given molar mass in $gmol^{-1}$ of Ca – 40; Cl – 35.5; H – 1.

- 1) 7.84L of H_2 gas is evolved.
- 2) 0.35 mol of H_2 gas is evolved.
- 3) The limiting reagent is calcium metal.
- 4) 33.3g of $CaCl_2$ is produced.

Key: 4

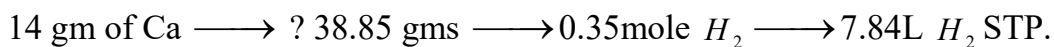
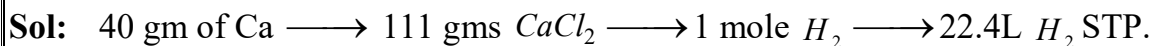

Section-II
(NUMERICAL VALUE Type)

This section contains **5 Numerical Value Type Questions**. The Answer should be within **0 to 9999**. If the Answer is in **Decimal** then round off to the **Nearest Integer** value (Example i.e. If answer is above **10** and less than **10.5** round off is **10** and If answer is from **10.5** and less than **11** round off is **11**).

Marking scheme: +4 for correct answer, 0 if not attempted and -1 in all other cases

71. Pre-exponential factors of two different reactions of same order are identical. Let activation energy of first reaction exceeds the activation energy of second reaction by 20 kJ mol⁻¹. If k_1 and k_2 are the rate constants of first and second reaction respectively at 300 K, then $\ln \frac{k_2}{k_1}$ will be _____.

(nearest integer) [R=8.3] K⁻¹ mol⁻¹]

Key: 8

Sol:
$$\ln \left(\frac{K_2}{K_1} \right) = \frac{Ea_2 - Ea_1}{RT} = \frac{20000}{8.314 \times 300} = 8$$

72. Consider the following reactions:

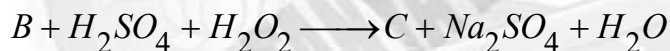
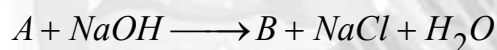
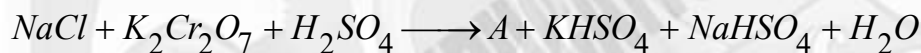

In the product 'C', 'X' is the number of O₂²⁻ units, 'Y' is the total number oxygen atoms present and 'Z' is the oxidation state of Cr. The value of X + Y + Z is _____.

Key: 13

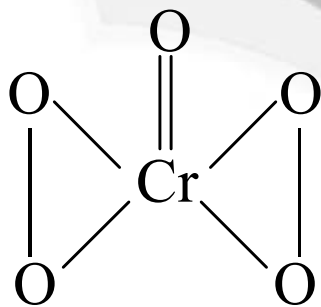
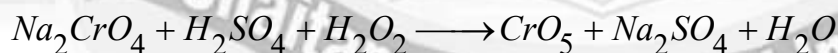
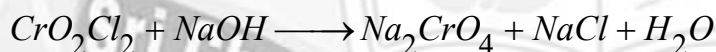
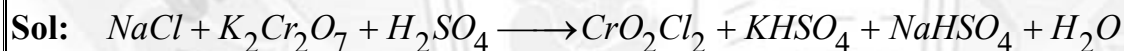

$$x = 2 \quad y = 5 \quad z = 6$$

$$x + y + z = 13$$

73. Consider the following reaction sequence

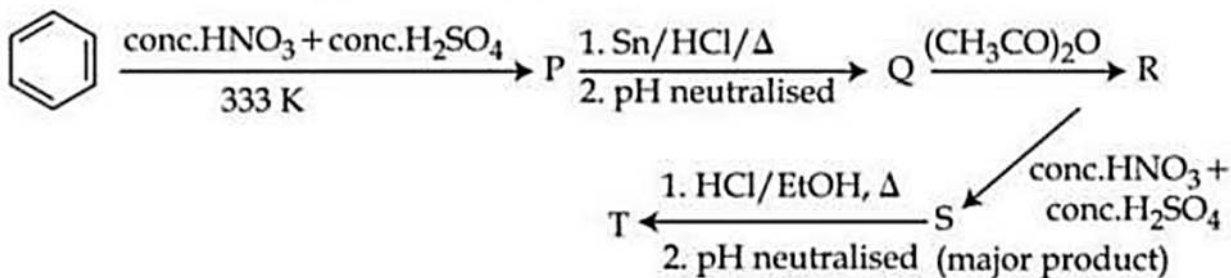

The percentage of nitrogen in product 'T' formed is _____%. (Nearest integer)

(Given molar mass in $g \text{ mol}^{-1}$ H: 1, C : 12, N : 14, O : 16)

Key: 20

Sol: The final product T is

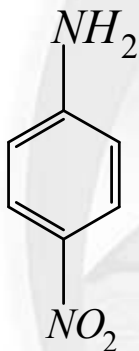

$$\% \text{ of nitrogen} = \frac{28}{138} \times 100 \approx 20\%$$

74. The pH and conductance of a weak acid (HX) was found to be 5 and $4 \times 10^{-5} S$, respectively. The conductance was measured under standard condition using a cell where the electrode plates having a surface area of 1 cm^2 were at a distance of 15 cm apart. The value of the limiting molar conductivity is _____ $S \text{ m}^2 \text{ mol}^{-1}$ (nearest integer) (Given: degree of dissociation of the weak acid (α) $\ll 1$)

Key: 6

Sol: $\text{pH} = 5 \Rightarrow [\text{H}^+] = 10^{-5} M$

$$C = 4 \times 10^{-5} = \frac{1}{R}$$

$$G^K = \frac{l}{a} = 15 \text{ cm}^{-1} = 1500 \text{ m}^{-1}$$

$$\therefore K = G \times C = 1500 \times 4 \times 10^{-5} = 6 \times 10^{-2} S \text{ m}^{-1} \Rightarrow m = \frac{K}{1000 \times M} = \frac{6 \times 10^{-2}}{10^3 \times 10^{-5}} = 6$$

75. Use the following data:

Substance	$\frac{\Delta_f H^\ominus(500K)}{kJ\ mol^{-1}}$	$\frac{S^\ominus(500K)}{JK^{-1}\ mol^{-1}}$
AB(g)	32	222
A ₂ (g)	6	146
B ₂ (g)	x	280

One mole each of A₂(g) and B₂(g) are taken in a 1 L closed flask and allowed to establish the equilibrium at 500K.

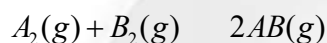

The value of x (in kJ mol⁻¹) is _____ (Nearest integer)

(Given: log K = 2.2 R = 8.3 J K⁻¹ mol⁻¹)

Key: 70

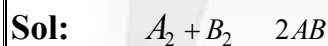

$$\Delta H_f \quad 6 \quad x \quad 2(32)$$

$$S^\ominus \quad 146 \quad 280 \quad 222$$

$$\Delta G^\ominus = -2.303RT \log K_e^2 = -2.303 \times 8.3 \times 500 \times 2.2 = -21.0264 \text{ KJ / mole}$$

$$\Delta H = 64 - 6 - x = (58 - x) \text{ KJ / mole}$$

$$\Delta S = 444 - 426 = 18 \text{ J / k / mole}$$

$$\therefore \Delta G = \Delta H - T\Delta S \Rightarrow \Delta H = \Delta G + T\Delta S = -21.026 + \frac{500 \times 18}{1000} = -12.026 \text{ KJ}$$

$$\Rightarrow 58 - x = -12 \Rightarrow x = 70 \text{ KJ / mole}$$



TOPPERS ARE NOT BORN, THEY'RE MADE @ SRI CHAITANYA

SEIZES 3 RANKS IN TOP 10 IN JEE MAIN 2025 (ALL-INDIA OPEN CATEGORY)



1
ALL INDIA RANK
OPEN CATEGORY
Ajay Reddy Vangala
Appl. No. 25030266193
Classroom Student from Grade 8B-XB



1
ALL INDIA RANK
OPEN CATEGORY
Devdutta Majhi
Appl. No. 25030018185*



10
All India Rank
Open Category
295
300
Marks
Saksham Jindal
Appl. No. 250310236696*

Secured 31 ranks in Top 100 All INDIA Open Category

 12 RANK SAURAV Appl. No. 250310254844*	 22 RANK LAKSHYA SHARMA Appl. No. 250310034153*	 31 RANK BANDARI RUSHMITH Appl. No. 250310395238	 32 RANK BHAVESH JAYANTHI Appl. No. 250310289939	 33 RANK UJJWAL KESARI Appl. No. 250310088880*	 36 RANK PRADISH GANDHI S Appl. No. 250310788252*
 39 RANK S SAI RISHANTH REDDY Appl. No. 250310589519	 41 RANK PRASANNA KS Appl. No. 250310328957	 43 RANK KOLLIBONA MUNI SAI Appl. No. 250310488895	 44 RANK GORRE NITHIN REDDY Appl. No. 250310551436	 53 RANK U RAMA CHARAN REDDY Appl. No. 250310280792	 56 RANK ARNAV NIGAM Appl. No. 250310326146
 60 RANK SAMUDRA SARKAR Appl. No. 250310179442*	 61 RANK SOHAN KALIDAS CHELEKAR Appl. No. 250310202114*	 64 RANK BUDUMURU VIKRAM RAJA Appl. No. 250310322700	 66 RANK SHAGANTI THRISHUL Appl. No. 250310500006	 70 RANK LAXIBHARGAV MENDE Appl. No. 250310240090	 71 RANK D CHETAN RAO Appl. No. 250310359884
 73 RANK V PRAVAS REDDY Appl. No. 250310253875	 75 RANK P SAI SURYA KARTHIK Appl. No. 250310407881	 76 RANK YASH KUMAR Appl. No. 250310204405*	 81 RANK P PRANAYA SAI MUKESH Appl. No. 250310308114	 89 RANK ADITYA SINGH Appl. No. 250310151728	 91 RANK JAY A GARWAL Appl. No. 250310122371*
 94 RANK V ESWAR KARTHIK Appl. No. 250310238425	 96 RANK SAKSHAM GARG Appl. No. 250310026728*	 97 RANK RANVEER SINGH VIRDE Appl. No. 250310799734			

BELOW 100

31

BELOW 500

95

BELOW 10

10

BELOW 100

98

BELOW 1000

579

TOTAL QUALIFIED RANKS FOR JEE ADVANCED-2025

22,094



LEADING BY MILES SRI CHAITANYA DOMINATES
JEE ADVANCED 2025

29 Ranks in Top 100 in All-India Open Category



4 Students in Top 11 in JEE-Advanced 2025, All India Open Category

16 RANK DEVUTTA MAJHI HT. No. 255053116*	18 RANK DHARMANA GNANA RUTVIK SAI HT. No. 256055278	19 RANK VANGALA AJAY REDDY HT. No. 256131009	23 RANK AKSH GOGI HT. No. 252071075*	26 RANK P HEMA SAI SURYA KARTHIK HT. No. 256033006	27 RANK SARKARSAMUDRA HT. No. 252071105*
30 RANK OM PRAKASH BEHERA HT. No. 252021018*	32 RANK SUNKARA SAI RISHANTH REDDY HT. No. 256185327	34 RANK DHRUBA JYOTHI PANJA HT. No. 252048248*	35 RANK BHAVESH JAYANTHI HT. No. 251049080	36 RANK ADVAY MAYANK HT. No. 252104113*	37 RANK KARMANYA GUPTA HT. No. 252081477*
42 RANK MD ANAS HT. No. 252046210*	45 RANK RAMIT GOYAL HT. No. 257001113*	52 RANK MAULIK JAIN HT. No. 252079407*	54 RANK GARV HT. No. 252066188*	59 RANK LARISSA HT. No. 252079071*	60 RANK ARYAN BALABADRULA HT. No. 256132077
63 RANK SAMYAJYOTI BISWAS HT. No. 253038456*	64 RANK AARUSH ANAND HT. No. 251806176*	72 RANK RUSHMITH BANDARI HT. No. 256168048	78 RANK KORIKANA RASAGNYA HT. No. 256057345	87 RANK LAKSHYA SHARMA HT. No. 252070079*	91 RANK AVANEESH BANSAL HT. No. 251113130*
95 RANK KAVYA AGGARWAL HT. No. 252079121*					

BELOW 100 ALL INDIA OPEN CATEGORY RANKS **29** | BELOW 500 ALL INDIA OPEN CATEGORY RANKS **113** | BELOW 1000 ALL INDIA OPEN CATEGORY RANKS **205** | BELOW 1000 ALL INDIA CATEGORY RANKS COUNT **745** | NUMBER OF QUALIFIED RANKS **4,212**