



PERFECT SCORE.

Excellence has a permanent address
- Sri Chaitanya.

JEE Main 2026 (Session 1)



PASALA MOHITH

Appl.No: 260310432915

CLASSROOM STUDENT

🎉 Congratulations To Parents, Teachers & Staff 🎉

#TransformingYourDreamsIntoReality

www.srichaitanya.net



📞 040-66 06 06 06



Sri Chaitanya
Educational Institutions



JEE MAIN 2026 - SESSION 2

02-04-2026 - Shift 1

**TOPPERS ARE NOT BORN,
THEY'RE MADE @ SRI CHAITANYA**

JEE MAIN 2025



AJAY REDDY VANGALA
HT. NO. 250310255592
CLASSROOM STUDENT FROM GRADE IX-XII

JEE ADV 2025



D. GNANA RUTVIK SAI
HT. NO. 256055278*

NEET 2025



KAVISH
HT. NO. 250411147966*
CLASSROOM STUDENT

SCAN FOR
VIDEO SOLUTIONS



Call Us Now: **040-66 06 06 06**

www.srichaitanya.net

Follow us    

#TransformingYourDreamsIntoReality



Sri Chaitanya IIT Academy.,India.

✦ A.P ✦ T.G ✦ KARNATAKA ✦ TAMILNADU ✦ MAHARASTRA ✦ DELHI ✦ M.P ✦ U.P ✦ HARYANA
✦ RAJASTHAN ✦ PUNJAB ✦ W.B ✦ ODISHA ✦ BIHAR

A right Choice for the Real Aspirant
ICON Central Office - Madhapur - Hyderabad

02-Apr-2026 Shift-I JEE Main-2026 Session-II (Apr)

MATHEMATICS

Max Marks: 100

Section-I

(SINGLE CORRECT ANSWER TYPE)

This section contains 20 Multiple Choice Questions. Each question has 4 options (1), (2), (3) and (4) for its answer, out of which ONLY ONE option can be correct.

Marking scheme: +4 for correct answer, 0 if not attempted and -1 in all other cases.

1. $\alpha, \alpha + 2 \in Z$ and $n \in Z$, where $\alpha, \alpha + 2$ are roots of equation

$$x(x+2) + (x+1)(x+3) + \dots + (x+n-1)(x+n+1) = 4n \text{ then } \alpha + n =$$

- 1) 0 2) 1 3) 2 4) 3

Key: (3)

Sol: $nx^2 + x(2+4+6+\dots+2n) + (1 \cdot 3 + \dots + (n-1)(n+1)) = 4n$

$$nx^2 + n(n+1)x + \frac{n(n+1)(2n+1)}{6} - 5n = 0$$

$$x^2 + (n+1)x + \frac{(n+1)(2n+1)}{6} - 5 = 0$$

D must be a perfect square

$$D = \frac{122 - 2n^2}{6} = 20 - \left(\frac{n^2 - 1}{3}\right)$$

If make perfect square $\Rightarrow \frac{n^2 - 1}{3} = 16 \Rightarrow n = 7$

So equation is $\Rightarrow x^2 + 8x + \frac{8 \times 15}{6} - 5 = 0$

$$x^2 + 8x + 15 = 0$$

$$x = -3, -5$$

$$\alpha = -5, \alpha + 2 = -3$$

$$\alpha + n = 7 - 5 = 2$$

2. Let x and y be real numbers such that $50 \left(\frac{2x}{1+3i} - \frac{y}{1-2i} \right) = 31 + 17i$, $i = \sqrt{-1}$. Then the value

of $10(x-3y)$ is

- 1) 20 2) 31 3) 35 4) 75

Key: (4)

Sol: $50 \left(\frac{2x(1-3i)}{10} + \frac{y(1+2i)}{5} \right) = 31 + 17i$

$$10x - 30xi - 10y - 20y = 31 + 17i$$

$$10(x - y) = 31, \quad -30x - 20y = 17$$

$$\text{Solving we get } x = \frac{9}{10}, \quad y = \frac{-11}{5}$$

$$\therefore 10(x - 3y) = 75$$

3. Let $\alpha, \beta \in R$ be such that system of linear equations

$$x + 2y + z = 5$$

$$2x + y + \alpha z = 5$$

$$8x + 4y + \beta z = 18$$

Has no solution. Then $\frac{\beta}{\alpha}$ is equal to :

1) -4

2) 4

3) 8

4) -8

Key: 2

$$\text{Sol: } \begin{vmatrix} 1 & 2 & 1 \\ 2 & 1 & \alpha \\ 8 & 4 & \beta \end{vmatrix} = 0$$

$$12\alpha - 3\beta = 0$$

$$\frac{\beta}{\alpha} = 4$$

4. Let $M = \begin{bmatrix} \alpha & 0 \\ 0 & \alpha \end{bmatrix}$ and $B = \begin{bmatrix} 3 & 3 \\ \beta & 2 \end{bmatrix}$. If $A^2 - 4A + I = O$ and $B^2 - 5B - 6I = O$, then among the two statements :

$$\text{(S1): } [(B - A)(B + A)]^T = \begin{bmatrix} 13 & 15 \\ 7 & 10 \end{bmatrix} \text{ and}$$

$$\text{(S2): } \det(\text{adj}(A + B)) = -5$$

1) Only (S1) is correct

2) Only (S2) is correct

3) Both (S1) and (S2) are correct

4) Both (S1) and (S2) are wrong

Key: 2

$$\text{Sol: } A^2 - 4A + I = 0 \Rightarrow \alpha = 3$$

$$B^2 - 5B - 6I = 0 \Rightarrow \beta = 4$$

$$[(B-A)(B+A)]^T = \begin{bmatrix} 13 & 7 \\ 15 & 10 \end{bmatrix}$$

S1 is wrong

$$\det(\text{adj}(A+B)) = -5$$

S2 is correct

5. Let A be the set of first 101 terms an A.P., whose first term is 1 and the common difference is 5 and let B be the set of first 71 terms of an A.P., whose first term is 9 and the common difference is 7. Then the number of elements in $A \cap B$, which are divisible by 3, is

- 1) 4 2) 5 3) 6 4) 7

Key: (2)

Sol: $AP_1: 1, 6, 11, \dots, 101$ terms

$AP_2: 9, 16, \dots, 71$ terms

$$D = L.C.M(d_1, d_2) = 35$$

1st common term is 16

$$T_n = 16 + (n-1)35$$

$$= 3k - (n+1)$$

$$n = 2, 5, 8, 11, 14$$

no of multiples of 3 is 5

6. The number of seven digits numbers that can be formed by using all the digits 1,2,3,5 and 7 such that each digit is used at least once, is:

- 1) 15400 2) 17800 3) 16800 4) 29400

Key: (3)

Sol: Exactly one digit repeated $\rightarrow {}^5C_1 \times \frac{7!}{3!} = 4200$

Exactly two digits repeated $\rightarrow {}^5C_2 \times \frac{7!}{2!2!} = 12600$

Total numbers = 16800

7. The number of elements in the set $S = \left\{ (r, k) : k \in Z \text{ and } {}^{36}C_{r+1} = \frac{6 \binom{35}{r}}{(k^2 - 3)} \right\}$, is :

- 1) 2 2) 4 3) 8 4) 16

Key: (2)

$$\text{Sol: } \frac{36}{r+1}, {}^{35}C_r = 6 \cdot \frac{{}^{35}C_r}{k^2 - 3}$$

$$k^2 - 3 = \frac{r+1}{6}$$

$$k^2 = \frac{r+19}{6}$$

$$0 \leq r \leq 35$$

$$19 \leq r+19 \leq 54$$

$$3.1 \leq 1 \frac{r+19}{6} \leq 9$$

$$\therefore k^2 = 4, 9$$

$$k = \pm 2, \pm 3$$

$$\therefore (r, k) \Rightarrow (5, \pm 2) \Rightarrow (35, \pm 3)$$

$$\therefore 4$$

8. If the mean of the data

Class	5-10	10-15	15-20	20-25	25-30	30-35
Frequency	2	K	28	54	k+1	5

is 21, then k is one of the roots of the equation

$$1) 2x^2 - 23x - 10 = 0 \quad 2) 4x^2 - 35x + 24 = 0 \quad 3) 2x^2 - 19x - 10 = 0 \quad 4)$$

$$2x^2 - 35x + 98 = 0$$

Key: 3

$$\text{Sol: } \bar{x} = \frac{\sum f_i x_i}{\sum f_i}$$

$$21 = \frac{1910 + 40k}{90 + 2k}$$

$$k = 10$$

9. Let the mid-points of sides of triangle ABC be $\left(\frac{5}{2}, 7\right), \left(\frac{5}{2}, 3\right)$ and $(4, 5)$. if its incentre is (h, k) then $3h+k$ is equal to :

1) 11

2) 12

3) 13

4) 14

Key: (3)**Sol:**

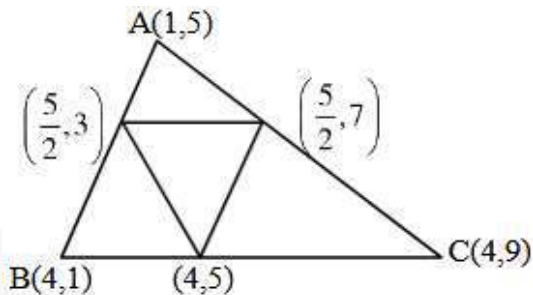

$$I = \left(\frac{24}{9}, 5 \right)$$

$$\therefore 3h + k = 8 + 5 = 13$$

10. Let an ellipse $\frac{x^2}{a^2} + \frac{y^2}{b^2} = 1$, $a < b$, pass through the point $(4, 3)$ and have eccentricity $\frac{\sqrt{5}}{3}$.

Then the length of its latus rectum is :

- 1) $\frac{4\sqrt{5}}{3}$ 2) $2\sqrt{5}$ 3) $\frac{7\sqrt{5}}{3}$ 4) $\frac{8\sqrt{5}}{3}$

Key: (4)

Sol: $\frac{16}{a^2} + \frac{9}{b^2} = 1 \rightarrow (1)$

$$e = \sqrt{\frac{b^2 - a^2}{b^2}} = \frac{\sqrt{5}}{3}$$

$$a = \frac{2}{3}b \rightarrow (2)$$

From 1 & 2

We get $a^2 = 20, b^2 = 45$

$$\text{Length of latusrectum} = \frac{8\sqrt{5}}{3}$$

11. If $\sin\left(\frac{\pi}{18}\right)\sin\left(\frac{5\pi}{18}\right)\sin\left(\frac{7\pi}{18}\right) = K$ then the value of $\sin\left(\frac{10K\pi}{3}\right)$ is :

- 1) $\frac{\sqrt{3}+1}{2\sqrt{2}}$ 2) $\frac{\sqrt{3}-1}{\sqrt{2}}$ 3) $\frac{\sqrt{3}}{2}$ 4) $\frac{1}{2}$

Key: (1)

Sol: $K = \sin 10^\circ \sin 50^\circ \sin 70^\circ$

$$= \frac{1}{4} \sin 30^\circ = \frac{1}{8}$$

$$\sin 10K \frac{\pi}{3} = \sin \left(10 \times \frac{1}{8} \cdot \frac{\pi}{3} \right) = \sin \frac{5\pi}{12} = \frac{\sqrt{3}+1}{2\sqrt{2}}$$

12. Let $S = \{x \in [-\pi, \pi] : \sin x(\sin x + \cos x) = a, a \in Z\}$. Then $n(S)$ is equal to :

- 1) 3 2) 6 3) 7 4) 9

Key: (4)

Sol: $\sin x(\sin x + \cos x) \in \left[\frac{1-\sqrt{2}}{2}, \frac{1+\sqrt{2}}{2} \right]$

2 integer will be there $\Rightarrow a = 0, 1$

If $a=0$ $\sin x(\sin x + \cos x) = 0$

$x = -\pi, 0, \pi$ or $\tan x = -1$

3 solutions $x = -\frac{\pi}{4}, \frac{3\pi}{4}$ 2 solutions

If $a=1$ $\sin x(\sin x + \cos x) = 1$

$\sin^2 x + \sin x \cos x = 1$

$2 \sin^2 x + 2 \sin x \cos x = 2$

$1 - \cos 2x + \sin 2x = 2$

$\sin 2x - \cos 2x = 1 \rightarrow$ square

$\sin 4x = 0$

$4x = -4\pi, -3\pi, \dots, 3\pi, 4\pi$

$x = -\pi, -\frac{3\pi}{4}, -\frac{\pi}{2}, -\frac{\pi}{4}, 0, \frac{\pi}{4}, \frac{\pi}{2}, \frac{3\pi}{4}, \pi$

$\Rightarrow x = -\frac{3\pi}{4}, -\frac{\pi}{2}, \frac{\pi}{4}, \frac{\pi}{2}$ 4 solutions

Total 9 solutions

13. If the point of intersection of the lines $\frac{x+1}{3} = \frac{y+a}{5} = \frac{z+b+1}{7}$ and $\frac{x-2}{1} = \frac{y-b}{4} = \frac{z-2a}{7}$ lies on xy -plane, then the value of $a+b$ is

- 1) 2 2) 5 3) 7 4) 9

Key: 3

Sol: $\frac{x+1}{3} = \frac{y+a}{5} = \frac{z+b+1}{7} = \lambda$

$\frac{x-2}{1} = \frac{y-b}{4} = \frac{z-2a}{7} = \mu$

$$(3\lambda - 1, 5\lambda - a, 7\lambda - b - 1) = (\mu + 2, 4\mu + b, 7\mu + 2a)$$

Put $z = 0$

$$7\lambda = b + 1 \rightarrow (1) \quad 7\mu + 2a = 0$$

$$2a = -7\mu \rightarrow (2)$$

$$3\lambda - \mu = 3 \rightarrow (3), \Rightarrow 4\lambda + \mu - 2 = 0 \rightarrow (4)$$

$$\text{From 3 \& 4 } \lambda = \frac{5}{7}, \mu = -\frac{6}{7}$$

$$a = 3, b = 4$$

$$\therefore a + b = 7$$

14. If \vec{a} and \vec{b} are two vectors such that $|\vec{a}| = 2$ and $|\vec{b}| = 3$, then the maximum value of

$$3\left|(3\vec{a} + 2\vec{b})\right| + 4\left|(3\vec{a} - 2\vec{b})\right| \text{ is :}$$

1) 30

2) 36

3) 60

4) 72

Key: (3)

$$\text{Sol: } E = 3\sqrt{9a^2 + 4b^2 + 12ab} + 4\sqrt{9a^2 + 4b^2 - 12ab}$$

$$= \sqrt{36 + 36 + 12 \times 6 \cos \theta} + 4\sqrt{36 + 36 - 12 \cos \theta}$$

$$= 18\sqrt{2}\sqrt{1 + \cos \theta} + 24\sqrt{2}\sqrt{1 - \cos \theta}$$

$$= 18\sqrt{2}\sqrt{2} \cos \frac{\theta}{2} + 24\sqrt{2} \left(\sqrt{2} \sin \frac{\theta}{2} \right)$$

$$= 36 \left(\cos \frac{\theta}{2} \right) + 48 \sin \left(\frac{\theta}{2} \right)$$

$$E_{\max} = \sqrt{(36)^2 + (48)^2} = 60$$

15. Let a line L passing through the point $(1, 1, 1)$ be perpendicular to both the vectors

$$\hat{i} + 2\hat{j} + 2\hat{k}, 2\hat{i} + 2\hat{j} + \hat{k}. \text{ If } P(a, b, c) \text{ is the foot of perpendicular from origin on the line L, then}$$

the value of $34(a + b + c)$ is :

1) 50

2) 80

3) 100

4) 120

Key: (3)

Sol: Direction vector of line is

$$= \begin{vmatrix} \hat{i} & \hat{j} & \hat{k} \\ 1 & 2 & 2 \\ 2 & 2 & 1 \end{vmatrix} = -2\hat{i} + 3\hat{j} - 2\hat{k}$$

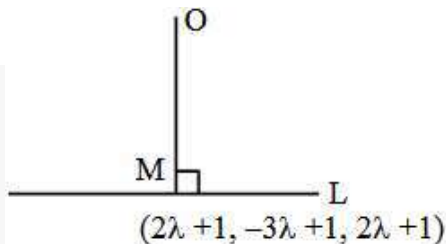

$$\frac{x-1}{2} = \frac{y-1}{-3} = \frac{z-1}{2}$$

So, equation of line is

$$\frac{x-1}{2} = \frac{y-1}{-3} = \frac{z-1}{2} = \lambda \text{ (let)}$$

Let $(2\lambda+1, -3\lambda+1, 2\lambda+1)$ be the foot of perpendicular from $(0,0,0)$ upon given line

$$\Rightarrow \overline{OM} \cdot (2\hat{i} - 3\hat{j} + 2\hat{k}) = 0$$

$$\Rightarrow 2(2\lambda+1) - 3(-3\lambda+1) + 2(2\lambda+1) = 0$$

$$\Rightarrow \lambda = -\frac{1}{17}$$

$$\text{So, } (a, b, c) = \left(\frac{-2}{17} + 1, \frac{3}{17} + 1, \frac{-2}{17} + 1 \right)$$

$$\Rightarrow 34(a+b+c) = 100$$

16. If $\lim_{x \rightarrow 2} \frac{\sin(x^3 - 5x^2 + ax + b)}{(\sqrt{x-1} - 1) \cdot \log_e(x-1)} = m$, then $a+b+m$ is equal to :

1) 5

2) 6

3) 8

4) 10

Key: (2)

Sol: \therefore Denominator = 0 at $x=2$

\Rightarrow Numerator = 0 at $x=2$

$$\Rightarrow 2^3 - 5(2)^2 + a(2) + b = 0$$

$$\Rightarrow 2a + b = 12 \dots \dots \dots (1)$$

$$\Rightarrow m = \lim_{x \rightarrow 2} 2 \left(\frac{x^3 - 5x^2 + ax + b}{(x-2)^2} \right)$$

$$\Rightarrow m = \lim_{x \rightarrow 2} 2 \left(\frac{3x^2 - 10x + a}{2(x-2)} \right)$$

\therefore Denominator = 0 at $x = 2$

\Rightarrow Numerator = 0 at $x = 2$

$$\Rightarrow 3(2)^2 - 10(2) + a = 0 \Rightarrow a = 8$$

Put $a=8$ in (1), we get $b=-4$

$$\therefore m = \lim_{x \rightarrow 2} 2 \left(\frac{6x - 10}{2} \right) \Rightarrow m = 2$$

$$\therefore a + b + m = 6$$

17. If the curve $y = f(x)$ passes through the point $(1, e)$ and satisfies the differential equation

$dy = y(2 + \log_e x) dx, x > 0$, then $f(e)$ is equal to :

- 1) e^e 2) e^{e^2} 3) e^{2e} 4) $e^{\frac{e}{2}}$

Key: 3

Sol: $\int \frac{dy}{y} = \int (2 + \log_e x) dx$

$$\log y = 2x + x \log x - x + c$$

$$\text{put } x = 1, y = e \Rightarrow c = 0$$

$$\log y = x + x \log x$$

$$\text{Put } x = e$$

$$\log_e y = 2e \Rightarrow y = e^{2e}$$

18. The number of critical points of the function $f(x) = \begin{cases} \left| \frac{\sin x}{x} \right|, & x \neq 0 \\ 1, & x = 0 \end{cases}$ in the interval

$(-2\pi, 2\pi)$ is equal to :

- 1) 1 2) 3 3) 5 4) 7

Key: (2)

Sol: We find points where $f(x) = 0$ or $f'(x)$ is not defined.

$$\therefore x = -\pi, 0, \pi \quad \therefore \text{3 points}$$

19. Let $[\cdot]$ denotes greatest integer function. Then the value of $\int_0^3 \left(\frac{e^x + e^{-x}}{[x]!} \right) dx$ is :

1) $e^2 + e^3 - \frac{1}{e^2} - \frac{1}{e^3}$

2) $\frac{1}{2} \left(e^2 + e^3 - \frac{1}{e^2} - \frac{1}{e^3} \right)$

3) $e^2 + e^3 - \frac{1}{2e^2} - \frac{1}{2e^3}$

4) $\frac{1}{2} (e^2 + e^3) - \frac{1}{e^2} - \frac{1}{e^3}$

Key: (2)

Sol: $\int_0^1 \frac{e^x + e^{-x}}{1} dx + \int_1^2 \frac{e^x + e^{-x}}{1} dx + \int_2^3 \frac{e^x + e^{-x}}{2} dx$

$$\int_0^2 e^x dx + \int_0^2 e^{-x} dx + \frac{1}{2} \int_2^3 (e^x + e^{-x}) dx$$

$$(e^2 - 1) + \frac{(e^{-2} - 1)}{-1} + \frac{1}{2} ((e^3 - e^2) - (e^{-3} - e^{-2}))$$

$$\frac{e^3 + e^2}{2} + 1 - 1 - \frac{e^{-2}}{2} - \frac{e^{-3}}{2}$$

$$\frac{e^3 + e^2 - e^{-2} - e^{-3}}{2}$$

20. Let $y = f(x)$ be the solution curve of the differential equation $(1 + \sin x) \frac{dy}{dx} + (y + 1) \cos x = 0$

$y(0) = 0$. If the curve $y = y(x)$ passes through the point $\left(\alpha, \frac{-1}{2} \right)$, then a value of α is :

1) $\frac{\pi}{6}$

2) $\frac{\pi}{4}$

3) $\frac{\pi}{3}$

4) $\frac{\pi}{2}$

Key: (4)

Sol: $\int \frac{dy}{y+1} + \int \frac{\cos x}{1+\sin x} dx = 0$

$$(y+1)(1+\sin x) = c$$

Put $x = 0, y = 0 \Rightarrow c = 1$

$$\Rightarrow (y+1)(1+\sin x) = 1$$

Put $x = \alpha, y = -\frac{1}{2} \Rightarrow \sin \alpha = 1$

$$\alpha = \frac{\pi}{2}$$

SECTION-II
(NUMERICAL VALUE TYPE)

Section-II contains 10 **Numerical Value Type** questions. Attempt any 5 questions only. If more than 5 questions attempted, First 5 Attempted questions will be considered. The Answer should be within **0 to 9999**. If the Answer is in **Decimal** then round off to the **nearest Integer** value (Example i.e. If answer is above 10 and less than 10.5 round off is 10 and if answer is from 10.5 and less than 11 round off is 11).

Marking scheme: +4 for correct answer, 0 if not attempt and -1 in all other cases.

21. If the domain of the function $f(x) = \sqrt{\log_{(0,6)} \left(\frac{2x-5}{x^2-4} \right)}$ is $(-\infty, a] \cup \{b\} \cup [c, d) \cup (e, \infty)$, then the value of $(a+b+c+d+e)$ is _____

Key: (4)

Sol: For domain $\log_{0.6} \frac{2x-5}{x^2-4} \geq 0$

$$\left| \frac{2x-5}{x^2-4} \right| \leq 1 \quad \& \quad x \neq \frac{5}{2} \dots\dots(1)$$

$$-1 \leq \frac{2x-5}{x^2-4} \leq 1$$

$$\frac{2x-5}{x^2-4} + 1 \geq 0$$

$$\frac{x^2+2x-9}{x^2-4} \geq 0$$

$$\frac{(x+1)^2-10}{(x-2)(x+2)} \geq 0$$

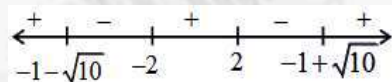

$$x \in (-\infty, -1-\sqrt{10}] \cup (-2, 2) \cup [-1+\sqrt{10}, \infty) \dots\dots(2)$$

$$\frac{2x-5}{x^2-4} - 1 \leq 0$$

$$\frac{2x-5-x^2+4}{x^2-4} \leq 0$$

$$\frac{x^2-2x+1}{x^2-4} \geq 0$$

$$\frac{(x-1)^2}{(x-2)(x+2)} \geq 0$$

$$x \in (-\infty, -2) \cup (2, \infty) \cup \{1\} \dots\dots(3)$$

$$(1) \cap (2) \cap (3)$$

$$x \in (-\infty, -1 - \sqrt{10}] \cup \{1\} \cup [-1 + \sqrt{10}, \frac{5}{2}) \cup (\frac{5}{2}, \infty)$$

$$a + b + c + d + e = -2 + 1 + 5 = 4$$

22. If $\sum_{k=1}^n a_k = 6n^3$, then $\sum_{k=1}^6 \left(\frac{a_{k+1} - a_k}{36} \right)^2$ is equal to _____

Key: (91)

Sol: $a_1 + a_2 + \dots + a_n = 6n^3$

$$a_1 + a_2 + \dots + a_n + a_{n+1} = 6(n+1)^3$$

$$a_{n+1} = 6(n+1)^3 - 6n^3$$

$$= 6((n+1) - n) = ((n+1)^2 + n^2 + n(n+1))$$

$$a_{n+1} = 6(1)(3n^2 + 3n + 1)$$

$$a_n = 6(3(n-1)^2 + 3(n-1) + 1)$$

$$= 6(3(n^2 - 2n + 1 + n - 1) + 1) = 6(3(n^2 - n) + 1)$$

$$a_n = 6(3n^2 - 3n + 1)$$

$$\sum_{k=1}^6 \left(\frac{6(3k^2 + 3k + 1 - 6(3k^2 - 3k + 1))}{36} \right)^2$$

$$\sum_{k=1}^6 \left(\frac{36k}{36} \right)^2 = \sum_{k=1}^6 k^2 = \frac{6 \times 7 \times 13}{6} = 91$$

23. Let $a, b, c \in \{1, 2, 3, 4\}$. If the probability, that $ax^2 + 2\sqrt{2}bx + c > 0$ for all $x \in R$, is $\frac{m}{n}$, $\gcd(m, n) = 1$, then $m+n$ is equal to _____

Key: (81)

Sol: $8b^2 - 4ac < 0 \Rightarrow 2b^2 < ac$

b	a	c	
1	1	3, 4	→ 2
1	2	2, 3, 4	→ 3
1	3	1, 2, 3, 4	→ 4
1	4	1, 2, 3, 4	→ 4
2	3	3, 4	→ 2
2	4	3, 4	→ 2

$$\text{Required probability} = \frac{17}{64} = \frac{m}{n}$$

$$\therefore m+n=17+64=81$$

24. Let a circle C have its centre in the first quadrant intersect the coordinate axes at exactly three points and cut off equal intercepts from the coordinate axes. If the length of the chord of C on the line $x+y=1$ is $\sqrt{14}$, then the square of the radius of C is _____

Key: (8)

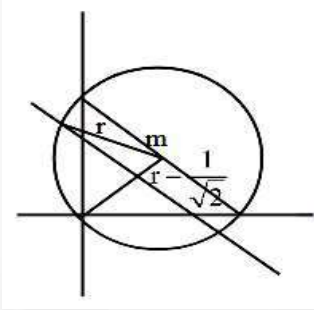

Sol:

$$r^2 = \left(\frac{\sqrt{14}}{2}\right)^2 + \left(r - \frac{1}{\sqrt{2}}\right)^2$$

$$r^2 = \frac{7}{2} + r^2 - \sqrt{2}r + \frac{1}{2}$$

$$\sqrt{2}r = 4$$

$$r = 2\sqrt{2}$$

$$r^2 = 8$$

25. If $\alpha = \int_0^{2\sqrt{3}} \log_2(x^2 + 4) dx + \int_2^4 \sqrt{2^x - 4} dx$, then α^2 is equal to _____

Key: (192)

$$\text{Sol: } \alpha = \int_0^{2\sqrt{3}} \log_2(x^2 + 4) dx + \int_2^4 \sqrt{2^x - 4} dx$$

By using Integral By parts

$$\alpha = 4(2\sqrt{3}) - 2(0) = 8\sqrt{3}$$

$$\therefore \alpha^2 = 192$$

PHYSICS

Max Marks: 100

SECTION-I
(SINGLE CORRECT ANSWER TYPE)

This section contains **20 Multiple Choice Questions**. Each question has 4 options (1), (2), (3) and (4) for its answer, out of which **ONLY ONE** option can be correct.

Marking scheme: +4 for correct answer, 0 if not attempted and -1 in all other cases.

26. The dimensional formula of

$\frac{1}{2} \epsilon_0 E^2$ ($\epsilon_0 = \text{permittivity of vacuum}$ and $E = \text{electric field}$) is $M^a L^b T^c$. The value of

$$2a - b + c = \underline{\hspace{2cm}}$$

1) 0

2) 1

3) -1

4) 2

Key: 2

Sol: $\frac{1}{2} \epsilon_0 E^2 = \text{Energy density} = \frac{\text{Energy}}{\text{Volume}}$

$$= \frac{ML^2T^{-2}}{L^3} = ML^{-1}T^{-2}$$

$$a=1 \quad b=-1 \quad c=-2$$

$$2a - b + c$$

$$2+1-2=1$$

27. The diameter of a wire measured by a screw gauge of least count 0.001 cm is 0.08 cm. The length measured by a scale of least count 0.1 cm is 150 cm. When a weight of 100 N is applied to the wire, the measured Young's modulus is $\alpha \times 10^9 \text{ N/m}^2$. The error in (ignore the contribution of the load to Young's modulus error calculation)

1) 1.3

2) 1.65

3) 0.13

4) 0.25

Key: 2

Sol: $Y = \frac{4WL}{\pi d^2 l} = 5.97 \times 10^{10} \text{ N/m}^2$

$$\frac{\Delta Y}{Y} = \frac{\Delta L}{L} + \frac{2\Delta d}{d} + \frac{\Delta l}{l}$$

$$\frac{\Delta Y}{5.97 \times 10^{10}} = \frac{0.1}{150} + \frac{2(0.001)}{0.08} + \frac{0.001}{0.5}$$

$$\Rightarrow \Delta Y = 1.65 \times 10^9 \text{ N/m}^2$$

28. The velocity of a particle is given as $\vec{v} = -x\hat{i} + 2y\hat{j} - z\hat{k} \text{ m/s}$. The magnitude of acceleration at point (1, 2, 4) is _____ m/s^2 .

- 1) $\sqrt{6}$ 2) 9 3) $\sqrt{33}$ 4) 0

Key: 2

Sol: $\vec{v} = -x\hat{i} + 2y\hat{j} - z\hat{k}$

$$\therefore V_x = \frac{dx}{dt} = -x, V_y = \frac{dy}{dt} = 2y, V_z = \frac{dz}{dt} = -z$$

$$a_x = -v_x \frac{dx}{dt} = -(-x) = x$$

$$a_y = 2 \frac{dy}{dt} = 2(2y) = 4y$$

$$a_z = -1 \frac{dz}{dt} = -(-z) = z$$

So, the acceleration $\vec{a} = +x\hat{i} + 4y\hat{j} + z\hat{k}$

Substituting the values $\vec{a} = \hat{i} + 8\hat{j} + 4\hat{k}$

$$a = \sqrt{1 + 64 + 16} = 9 \text{ m/s}$$

29. The position of an object having mass 0.1 kg as a function of time t is given as

$$\vec{r} = (10t^2\hat{i} + 5t^3\hat{j}) \text{ m}. \text{ At } t = 1 \text{ s, which of the following statements are correct?}$$

A) The linear momentum $\vec{p} = (2\hat{i} + 1.5\hat{j}) \text{ kg.m/s}$.

B) The force acting on the object $\vec{F} = (2\hat{i} + 3\hat{j}) \text{ N}$.

C) The angular momentum of the object about its origin $\vec{L} = 15\hat{k} \text{ Js}$.

D) The torque acting on the object about its origin $\vec{\tau} = 20\hat{k} \text{ Nm}$.

Choose the correct answer from the options given below.

- 1) A, B and C only 2) B, C and D only
3) A, C and D only 4) A, B and D only

Key: 4

Sol: $\vec{v} = 20t\hat{i} + 15t^2\hat{j}$

$$\vec{a} = 20\hat{i} + 30t\hat{j}$$

$$\text{(Force)} \quad \vec{F}_{t=1} = 2\hat{i} + 3\hat{j}; \quad \vec{P}_{t=1} = m\vec{v} \text{ (momentum)}$$

$$= 2\hat{i} + 1.5\hat{j}$$

Angular momentum

$$\vec{L}_{t=1} = \vec{r} \times \vec{P}$$

$$= (10\hat{i} + 5\hat{j}) \times (2\hat{i} + 1.5\hat{j})$$

$$= 15\hat{k} - 10\hat{k}$$

$$= 5\hat{k}$$

$$\text{Torque } \vec{\tau} = \vec{r} \times \vec{F}$$

$$= (10\hat{i} + 5\hat{j}) \times (2\hat{i} + 3\hat{j})$$

$$= 20\hat{k}$$

30. A planet (P_1) is moving around the star of mass $2M$ in the orbit of radius R . Another planet (P_2) is moving around another star of mass $4M$ in a orbit of radius $2R$. Ratio of time periods of revolution of P_2 and P_1 is _____

1) $\frac{1}{2}$

2) 2

3) 4

4) $\frac{1}{4}$

Key: 1

$$\text{Sol: } T = \frac{2\pi}{\sqrt{GM_s}} r^{3/2}$$

$$\frac{T_1}{T_2} = \sqrt{\frac{M_{s2}}{M_{s1}}} \left(\frac{r_1}{r_2}\right)^{3/2}$$

$$= \sqrt{\frac{4M}{2M}} \left(\frac{R}{2R}\right)^{3/2}$$

$$= \sqrt{2} \left(\frac{1}{2}\right)^{3/2} = \sqrt{2} \frac{1}{\sqrt{8}}$$

$$= \frac{1}{2}$$

$$\frac{T_1}{T_2} = \frac{1}{2}$$

31. A particle is rotating in a circular path and at any instant its motion can be described as

$$\theta = \frac{5t^4}{40} - \frac{t^3}{3}. \text{ The angular acceleration of the particle after 10 seconds is } \underline{\hspace{2cm}}$$

rad / s²

- 1) 150 2) 120 3) 130 4) 170

Key: 3

Sol: $\theta = \frac{5t^4}{40} - \frac{t^3}{3}$

$$\omega = \frac{d\theta}{dt} = \frac{5}{40} \times 4t^3 - \frac{3}{3}t^2$$

$$\omega = \frac{t^3}{2} - t^2$$

$$\alpha = \frac{d\omega}{dt} = \frac{3}{2}t^2 - 2t$$

$$t = 10 \text{ sec, } \alpha = \frac{3}{2}(10)^2 - 2(10)$$

$$\alpha = 130$$

32. A parallel plate air capacitor has a capacitance C. When it is half filled as shown in figure with a dielectric constant $K = 5$, the percentage increase in the capacitance is _____

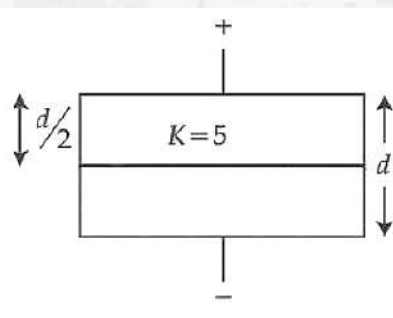

- 1) 33.34 2) 66.67 3) 200 4) 400

Key: 2

Sol: $C_i = \frac{A\epsilon_0}{d}$

$$\frac{1}{C_f} = \frac{d/2}{A\epsilon_0} + \frac{d/2}{A\epsilon_0 \cdot 5} = \frac{d}{2A\epsilon_0} + \frac{d}{10A\epsilon_0} = \frac{6d}{10A\epsilon_0} = \frac{3d}{5A\epsilon_0}$$

$$C_f = \frac{5A\epsilon_0}{3d}$$

$$\Delta C = C_f - C_i = \frac{2}{3} \frac{A\epsilon_0}{d}$$

$$\% \text{ increase} = \frac{\Delta C}{C} \times 100 = \frac{2}{3} \times 100 = 66.67\%$$

33. Heat is supplied to a diatomic gas at constant pressure. Then the ratio of $\Delta Q : \Delta U : \Delta W$ is

- 1) 2 : 3 : 5 2) 5 : 3 : 2 3) 2 : 5 : 7 4) 7 : 5 : 2

Key: 4

Sol: $W = P\Delta V = nR\Delta T$

$$\Delta U = nC_v\Delta T = n \frac{f}{2} R\Delta T = n \frac{5}{2} R\Delta T$$

$$Q = \frac{7}{2} nR\Delta T$$

$$\frac{Q}{W} = \frac{7}{2}$$

$$\frac{\Delta U}{W} = \frac{5}{2}$$

$Q : \Delta U : W$ is 7 : 5 : 2

34. Two charged conducting spheres S_1 and S_2 of radii 8 cm are connected to each other by a wire. After equilibrium is established, the ratio of electric fields on S_1 and S_2 spheres are E_{S1} and E_{S2} respectively. The value of $\frac{E_{S1}}{E_{S2}}$ is _____

- 1) $\frac{3}{2}$ 2) $\frac{2}{3}$ 3) $\frac{4}{9}$ 4) $\frac{9}{4}$

Key: 4

Sol: $V_1 = V_2$

$$\frac{kq_1}{r_1} = \frac{kq_2}{r_2}$$

$$\frac{q_1}{q_2} = \frac{r_1}{r_2}$$

$$\frac{E_1}{E_2} = \frac{q_1 r_2^2}{q_2 r_1^2} = \frac{r_2}{r_1} = \frac{18}{8} = \frac{9}{4}$$

35. The equation of a plane progressive wave is given by $y = 5 \cos \pi \left(200t - \frac{x}{150} \right)$ where x

and y are in cm and t is in second. The velocity of the wave is _____ m/s

- 1) 120 2) 150 3) 200 4) 300

Key: 4

Sol: $\omega = 200\pi$

$$k = \frac{\pi}{150}$$

$$v = \frac{\omega}{k} = \frac{200}{\left(\frac{1}{150}\right)} = 200 \times 150$$

$$= 3 \times 10^4 \text{ cm/s}$$

$$= 300 \text{ m/s}$$

36. Two short electric dipoles A and B having dipole moment p_1 and p_2 respectively are placed with their axis mutually perpendicular as shown in the figure. The resultant electric field at a point x is making an angle of 60° with the line joining points O and x . The ratio of the dipole moments p_2 / p_1 is _____

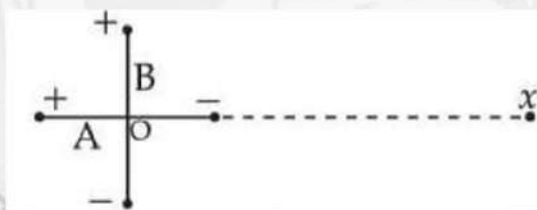

- 1) $\frac{\sqrt{3}}{2}$ 2) $2\sqrt{3}$ 3) $\frac{1}{\sqrt{3}}$ 4) $\sqrt{3}$

Key: 2

Sol:

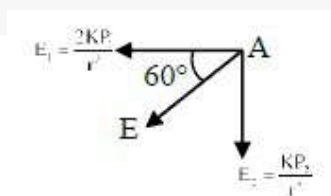

$$\tan 60^\circ = \frac{E_2}{E_1} = \frac{P_2}{2P_1}$$

$$\sqrt{3} = \frac{P_2}{2P_1}$$

$$\frac{P_2}{P_1} = 2\sqrt{3}$$

37. For the given circuit (shown in part (A)) the time dependent input voltage $v_m(t)$ and corresponding output $v_o(t)$ are shown in part (B) and part (C), respectively. Identify the components that are used in the circuit between points X and Y.

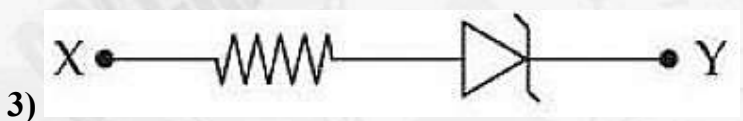
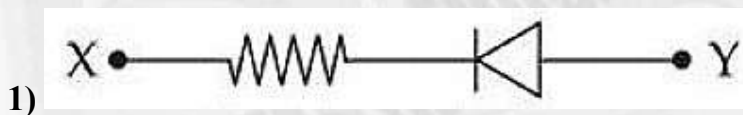
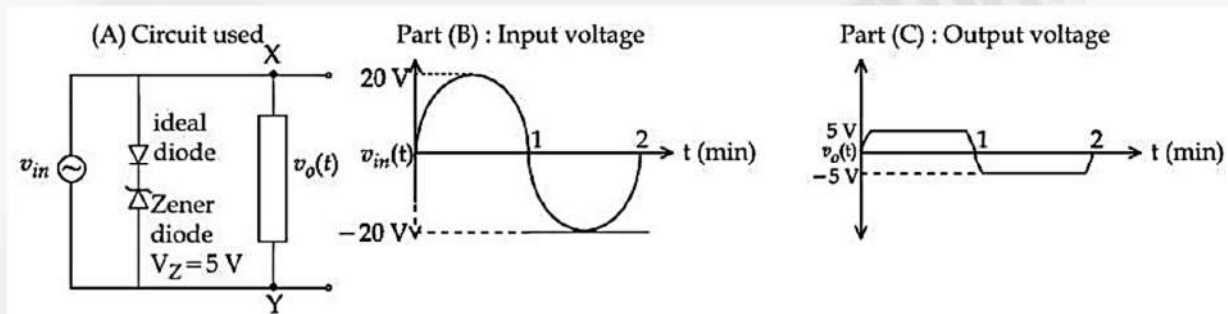

Key: 2

Sol: Conceptual

38. When a coil is placed in a time dependent magnetic field the power dissipated in it is P . The number of turns, area of the coil and radius of the wire are N , A and r respectively. For a second coils number of turns, area of the coil and radius of the coil wire are $2N$, $2A$ and $3r$ respectively. When the first coil is replaced with second coil the power dissipated in it is $\sqrt{2} \alpha P$. The value of α is _____

1) 36

2) $128\sqrt{2}$

3) 16

4) 64

Key: 1

$$\text{Sol: } \frac{P_2}{P_1} = \frac{N_2}{N_1} \cdot \left(\frac{A_2}{A_1}\right)^{3/2} \cdot \left(\frac{r_2}{r_1}\right)^2$$

$$\frac{P_2}{P} = \left(\frac{2N}{N}\right) \cdot \left(\frac{2A}{A}\right)^{3/2} \cdot \left(\frac{3r}{r}\right)^2$$

$$P_2 = 36\sqrt{2}P$$

39. Two identical long current carrying wires are bent into the shapes shown in the following figures. If the magnitude of magnetic fields at the centres P and Q of a semicircular arc are B_1 and B_2 respectively, then the ratio $\frac{B_1}{B_2}$ is _____

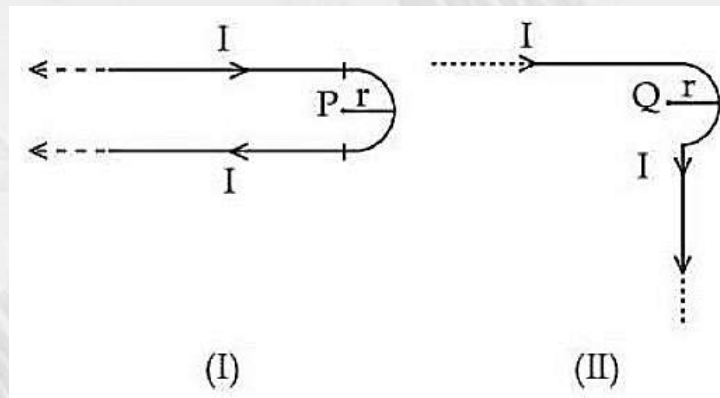

1) $\frac{2+\pi}{1+\pi}$

2) $\frac{1+\pi}{1-\pi}$

3) $\frac{2+\pi}{1-\pi}$

4) $\frac{1+\pi}{2-\pi}$

Key: 1

$$\text{Sol: } B_1 = \frac{\mu_0 I}{2\pi R} + \frac{\mu_0 I}{4R}$$

$$B_2 = \frac{\mu_0 I}{4\pi R} + \frac{\mu_0 I}{4R}$$

$$\frac{B_1}{B_2} = \left(\frac{2+\pi}{1+\pi}\right)$$

40. For a thin symmetric prism made of glass (refractive index 1.5), the ratio of incident angle and minimum deviation will be _____

1) 3 : 4

2) 3 : 2

3) 2 : 1

4) 1 : 2

Key: 2**Sol:** For small angle

$$10\mu_1 \sin(i) = \mu_2 \sin(r)$$

$$(1) i = (\mu)(r)$$

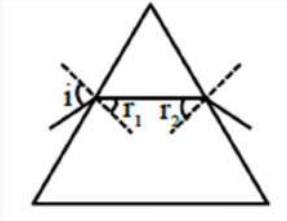

$$\text{and } r_1 = r_2 = \frac{A}{2}$$

$$i = (\mu) \left(\frac{A}{2} \right)$$

$$\delta_{\min} = (\mu - 1)A$$

$$\frac{i}{\delta_{\min}} = \frac{(\mu)(A/2)}{(\mu - 1)A} = \frac{\mu}{2(\mu - 1)} = \frac{1.5}{2(0.5)}$$

$$= 3/2$$

$$\frac{i}{\delta_{\min}} = \frac{3}{2}$$

41. Refer the figure given below. μ_1 and μ_2 are refractive indices of air and lens material.

The height of image will be _____ cm

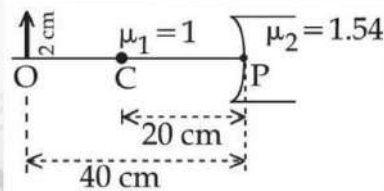

1) 1

2) 0.5

3) 1.2

4) 0.25

Key: 1

$$\text{Sol: } \frac{\mu_2}{v} - \frac{\mu_1}{u} = \frac{\mu_2 - \mu_1}{R}$$

$$\frac{1.54}{v} - \frac{1}{(-40)} = \frac{1.54 - 1}{-20}$$

$$\frac{1.54}{v} = -\frac{1.54}{20} - \frac{1}{40}$$

$$\frac{1.54}{v} = -\frac{2.08}{40}$$

$$v = -29.61 \text{ cm}$$

$$\frac{h_i}{h_0} = \frac{\mu_1 v}{\mu_2 u} = \frac{1 \times (-29.61)}{1.54 \times (-40)}$$

$$\frac{h_i}{h_0} = 0.48$$

$$h_i = 0.48 \times 2 = 0.96 \text{ cm} \Rightarrow 1 \text{ cm}$$

42. For a certain metal, when monochromatic light of wavelength λ is incident, the stopping potential for photoelectrons is $3V_0$. When the same metal is illuminated by light of wavelength 2λ , then the stopping potential becomes V_0 . The threshold wavelength for photoelectric emission for the given metal is $\alpha\lambda$. The value of α is _____

- 1) 1 2) 4 3) 2 4) 3

Key: 2

Sol: $\frac{hC}{\lambda} - \phi = 3eV_0 \dots\dots (i)$

$$\frac{hC}{2\lambda} - \phi = eV_0 \dots\dots (ii)$$

$$\frac{hC}{\lambda} - \phi = \frac{3hC}{2\lambda} - 3\phi$$

$$2\phi = \frac{hC}{2\lambda}$$

$$\phi = \frac{hC}{4\lambda} = \frac{hC}{\lambda_{th}}$$

$$\therefore \lambda_{th} = 4\lambda$$

43. An electromagnetic wave travelling in x-direction is described by field equation

$$E_y = 300 \sin \omega \left(t - \frac{x}{c} \right).$$

If the electron is restricted to move in y-direction only with

speed of $1.5 \times 10^6 \text{ m/s}$ then ratio of maximum electric and magnetic forces acting on the electron is _____

- 1) 200 2) 150 3) 400 4) 300

Key: 1

Sol: $V_{wave} = \frac{w}{k} = \frac{w}{w/c} = c = 3 \times 10^8 \text{ m/s}$

$$\frac{F_{Electric}}{F_{Magnetic}} = \frac{C}{V}$$

$$= \frac{3 \times 10^8}{1.5 \times 10^6} = 2 \times 10^2$$

44. Angular momentum of an electron in a hydrogen atom is $\frac{3h}{\pi}$, then the energy of the

electron is _____ eV.

- 1) -1.51 2) -0.85 3) -0.38 4) -0.28

Key: 3

Sol: $L = \frac{nh}{2\pi} = \frac{3h}{\pi}; n = 6$

$$E = \frac{-13.6}{n^2} = \frac{-13.6}{36} = -0.38 \text{ eV}$$

45. A liquid drop of diameter 2 mm breaks into 512 droplets. The change in surface energy is $\alpha \times 10^{-6} \text{ J}$. The value of α is _____. (Take surface tension of liquid = 0.08 N/m)

- 1) 10 2) 7 3) 8 4) 11

Key: 2

Sol: Vol^m constant

$$V_1 = V_2$$

$$R = n^{1/3} \cdot r$$

$$1 = (512)^{1/3} \cdot r$$

$$r = \frac{1}{8} \text{ mm}$$

$$\Rightarrow \Delta SE = SE_2 - SE_1 = T \times 4\pi r^2 \times n - T \times 4\pi R^2 = T \times 4\pi \{nr^2 - R^2\}$$

$$= 0.08 \times 4\pi \left\{ 512 \times \left(\frac{1}{8}\right)^2 - 1^2 \right\} \times 10^{-6}$$

$$= 0.08 \times 4\pi \{7\} \times 10^{-6} = 7.034 \times 10^{-6}$$

SECTION-II
(NUMERICAL VALUE TYPE)

This section contains **5 Numerical Value Type Questions**. The Answer should be within **0 to 9999**. If the Answer is in **Decimal** then round off to the **Nearest Integer** value (Example I.e. If answer is above **10** and less than **10.5** round off is **10** and If answer is from **10.5** and less than **11** round off is **11**).

Marking scheme: +4 for correct answer, 0 if not attempt and -1 in all other cases

46. In single slit diffraction pattern, the wavelength of light used is 628 nm and slit width is 0.2 mm the angular width of central maximum is $\alpha \times 10^{-2}$ degrees. The value of α is _____

Key: 36

Sol: angular of width of central maxima $= \frac{2\lambda}{d}$

$$= \frac{2 \times 628 \times 10^{-9}}{0.2 \times 10^{-3}}$$

$$= 628 \times 10^{-5} \times \frac{180}{\pi}$$

$$= 35981.74 \times 10^{-5} = 0.36^0$$

47. A vessel contains $0.15m^3$ of a gas at pressure 8 bar and temperature 140^0C with $c_p = 3R$ and $c_v = 2R$. It is expanded adiabatically till pressure falls to 1 bar. The work done during this process is _____ k J. (R is gas constant)

Key: 120

Sol: $P_1V_1^y = P_2V_2^y$

$$y = \frac{C_p}{C_v} = \frac{3}{2}$$

$$V_2 = \left(\frac{P_1}{P_2} \right)^{1/y} \cdot V_1$$

$$V_2 = (8)^{2/3} \times 0.15 = 4 \times 0.15 = 0.6$$

$$\omega = \frac{P_2V_2 - P_1V_1}{1-y} \Rightarrow \left\{ \frac{1 \times 0.6 - 8 \times 0.15}{1 - \frac{3}{2}} \right\} \times 10^5$$

$$= \left\{ \frac{0.6 - 1.2}{-0.5} \right\} \times 10^5 = \frac{0.6}{0.5} \times 10^5 \Rightarrow 1.2 \times 10^5 \Rightarrow 120KJ$$

48. $1\mu C$ charge moving with velocity $\vec{v} = (\hat{i} - 2\hat{j} + 3\hat{k}) m/s$ in the region of magnetic field $\vec{B} = (2\hat{i} + 3\hat{j} - 5\hat{k}) T$. The magnitude of force acting on it is $\sqrt{\alpha} \times 10^{-6} N$. The value of α is _____

Key: 171

Sol: $\vec{F} = q(\vec{V} \times \vec{B})$

$$\vec{F} = 1 \times 10^{-6} [(\hat{i} - 2\hat{j} + 3\hat{k}) \times (2\hat{i} + 3\hat{j} - 5\hat{k})]$$

$$\vec{F} = 10^{-6} (\hat{i} + 11\hat{j} + 7\hat{k})$$

$$|\vec{F}| = \sqrt{171} \times 10^{-6}$$

49. A uniform wire of length l of weight w is suspended from the roof with a weight of W at the other end. The stress in the wire at $\frac{l}{3}$ distance from the top is $\left(\frac{W}{A} + \frac{2w}{\gamma A}\right)$, where, A is the cross sectional area of the wire. The value of γ is _____

Key: 3

Sol: Stress at $\frac{l}{3}$

$$\frac{T}{A} = \frac{W + \frac{2w}{3}}{A} = \frac{W}{A} + \frac{2w}{3A}$$

$$\gamma = 3$$

50. A tub is filled with water and a wooden cube $10cm \times 10cm \times 10cm$ is placed in the water. The wooden cube is found to float on the water with a part of it submerged in water. When a metal coin is placed on the wooden cube, the submerged part is increased by 3.87 cm. The mass of the metal coin is _____ gram.
(Take water density as $1 g/cm^3$ and density of wood as $0.4 g/cm^3$)

Key: 387

Sol: $F_B' - F_B = mg$

$$mg = 3.87 A \rho_L g$$

$$m = 3.87 \times 100 \times 1 = 387$$

CHEMISTRY**Max Marks: 100****Section-I
(SINGLE CORRECT ANSWER TYPE)**

This section contains **20 Multiple Choice Questions**. Each question has 4 options (1), (2), (3) and (4) for its answer, out of which **ONLY ONE** option can be correct.

Marking scheme: +4 for correct answer, 0 if not attempted and -1 in all other cases.

51. The mass of iron converted into Fe_3O_4 by the action of 18g of steam is
(Given :Molar mass of H, O and Fe are 1,16 and 56 $g\ mol^{-1}$ respectively)
Assume iron is present in excess.
- 1) 2.1 gm 2) 4.2 gm 3) 21 gm 4) 42 gm

Key: (4)

$$n_{steam} = \frac{18}{18} = 1$$

$$n_{Fe\text{ required}} = \frac{3}{4}$$

$$\text{Mass of Fe required} = \frac{3}{4} \times 56 = 42\text{ gm}$$

52. What is the energy (in $J\ atom^{-1}$) required for the following process?

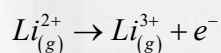

(Take the ionization energy for the H atom in the ground state as $2.18 \times 10^{-18}\ J\ atom^{-1}$)

- 1) 8.72×10^{-18} 2) 1.962×10^{-18} 3) 1.962×10^{-17} 4) 6.542×10^{-17}

Key: 3

Sol: IE = Ionisation of Hydrogen $\times z^2$

$$2.18 \times 10^{-18} \times 3^2 = 19.62 \times 10^{-18} = 1.962 \times 10^{-17}$$

53. Given below are two statements

Statement-I : The correct sequence of bond length in the following species is

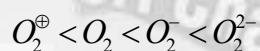

Statement-II : The correct sequence of number of unpaired electrons in the following species is $O_2 > O_2^{+} > O_2^{-} > O_2^{2-}$

In the light of the above statements choose the correct answers from the options given below

- 1) Both Statement-I and Statement-II are true
2) Both Statement-I and Statement-II are false
3) Statement-I is true but Statement-II is false
4) Statement-I is false but Statement-II is true

Key: (3)

Sol: Species Bond order unpaired electrons

O_2^{\oplus}	2.5	1
O_2	2	2
O_2^-	1.5	1
O_2^{2-}	1	0

54. Consider the following data

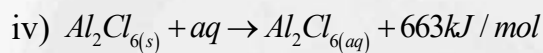
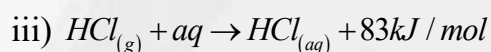
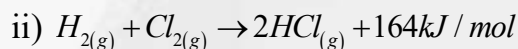
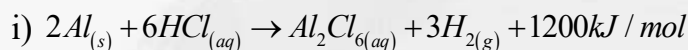

The enthalpy of formation of anhydrous solid Al_2Cl_6 is :

- 1) $-648kJ mol^{-1}$ 2) $-1350kJ mol^{-1}$ 3) $-2002kJ mol^{-1}$ 4) $-1527kJ mol^{-1}$

Key: 4

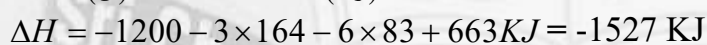
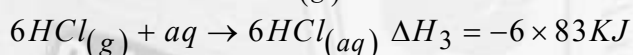
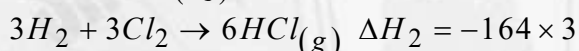
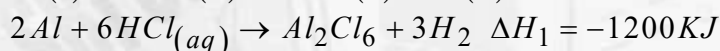
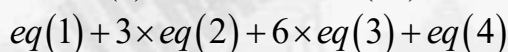
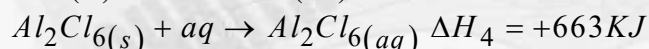
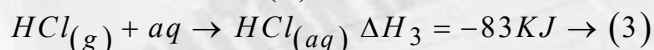
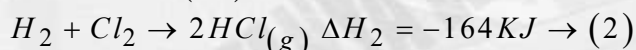
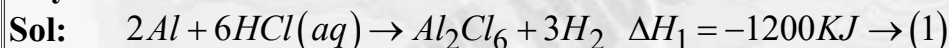

55. 19.5 g of fluoro acetic acid (molar mass = 78 g mol^{-1}) is dissolved in 500g of water at

298K. The depression in the freezing point of water was $1^{\circ}C$. What is k_a of fluoro acetic acid? (For water, $K_f = 1.86 K kg mol^{-1}$). Assume molarity and molality to have same values.

- 1) 10^{-6} 2) 4×10^{-4} 3) 3×10^{-5} 4) 3×10^{-3}

Key: (4)

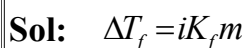

$$1 = i \times 1.86 \times \frac{1/4}{1/2}$$

$$i = \frac{2}{1.86}$$

$$i = 1 + (n-1)\alpha$$

$$i = 1 + \alpha$$

$$\alpha = \frac{2}{1.86} - 1 = 0.075$$

$$K_a = C\alpha^2$$

$$= \frac{1}{2} \times (0.075)^2$$

$$= 0.00281 = 2.8 \times 10^{-3} = 3 \times 10^{-3}$$

56. The solubility product constants of Ag_2CrO_4 and $AgBr$ are $32x$ and $4y$ respectively at 298K. The value of $\left(\frac{\text{molarity of } Ag_2CrO_4}{\text{molarity of } AgBr}\right)$ can be expressed as :

1) $\frac{2\sqrt[3]{x}}{y}$

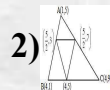

3) $\sqrt{\frac{x}{y}}$

4) $\frac{\sqrt[3]{x}}{\sqrt{y}}$

Key: (4)

Sol: For Ag_2CrO_4

$$4S_1^3 = 32x \quad \Rightarrow S_1 = 2\sqrt[3]{x}$$

For $AgBr$

$$S_2^2 = 4Y \quad \Rightarrow S_2 = 2Y^{1/2}$$

$$\text{Ratio} \left(\frac{S_1}{S_2}\right) = \frac{\sqrt[3]{x}}{\sqrt{y}}$$

57. An electrochemical cell is constructed using half cells in the direction of spontaneous change

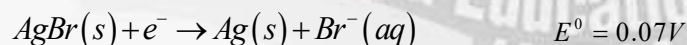
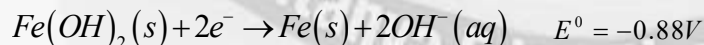

Which of the following option is correct



2) $E_{cell}^0 = -0.95 V$

3) Fe is reduced in the electrochemical cell

4) E_{cell}^0 is an extensive property

Key: (1)

Sol: $E_{cell}^0 = E_{R(cathode)}^0 - E_{R(anode)}^0$
 $= 0.07 - (-0.88) = 0.95V$

58. $t_{100\%}$ is the time required for the 100% completion of the reaction while $t_{1/2}$ is the time required for the 50% of the reaction to be completed which of the following option correctly represents relation between $t_{100\%}$ and $t_{1/2}$ for zero and first order reactions respectively?

- 1) $t_{100\%} = (t_{1/2})^2$ and $t_{100\%} = (t_{1/2})^{-\infty}$ 2) $t_{100\%} = 2 \times t_{1/2} : t_{100\%} = (t_{1/2})^{\infty}$
 3) $t_{100\%} = 2 \times t_{1/2} : t_{100\%} = (2t_{1/2})^2$ 4) $t_{100\%} = (t_{1/2})^{\infty} : t_{100\%} = 2t_{1/2}$

Key: (2)**Sol:** Zero-order

$$t_{100\%} = \frac{a}{k}; t_{1/2} = \frac{a}{2k}$$

1st Order

$$t_{100\%} = \infty$$

$$t_{1/2} = \frac{\ln 2}{k}$$

59. Given below are two statements

Statement – I : The first Ionization enthalpy of the elements *Na, Mg, Cl* and *Ar* follows the order $Na > Mg > Cl > Ar$

Statement – II : Among *Ca, Al, Fe* and *B*, the third ionisation enthalpy is very high for *Ca*.

In the light of the above statements choose the correct answers from the options given below

- 1) Both Statement-I and Statement-II are true
 2) Both Statement-I and Statement-II are false
 3) Statement-I is true but Statement-II is false
 4) Statement-I is false and Statement-II is true

Key: (2)**Sol:** Statement I $IE: Ar > Mg > Al > Na$

Statement II : Boron is the highest 3rd Ionisation enthalpy

60. Given below are two statements :

Statement I : Oxidising power of halogens decreases in the order $F_2 > Cl_2 > Br_2 > I_2$ which is the basis of “Layer test”

Statement II : “Layer test” to identify Br_2 and I_2 in aqueous solution involves the oxidation of bromide or iodide into Br_2 or I_2 respectively with Cl_2 , which is a type of displacement redox reaction.

In the light of the above statements choose the correct answers from the options given below

- 1) Both Statement-I and Statement-II are true
- 2) Both Statement-I and Statement-II are false
- 3) Statement-I is true but Statement-II is false
- 4) Statement-I is false but Statement-II is true

Key: 1

Sol: Statement I is true. The oxidising power of halogen's follows the order

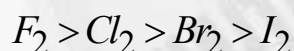

Which is the basis of layer test

A stronger oxidising agent can oxidise the halide of weaker oxidising agent like

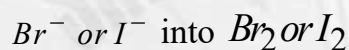

Statement II is also true

Layer test involves adding Cl_2 under to an Aq. Solutions containing Br^- or I^- ions

The Cl_2 oxidises these ions to their respective elemental halogens

61. Which of the following sets includes all the species that will change the orange colour of $K_2Cr_2O_7$ in acidic medium?

- | | |
|-------------------------------------|------------------------------------------|
| 1) $Fe^{2+}, Sn^{2+}, I^-, S^{2-}$ | 2) $S^{2-}, Fe^{3+}, I^-, C_2O_4^{2-}$ |
| 3) $Fe^{2+}, NO_2^-, SO_2, Sn^{4+}$ | 4) $Fe^{3+}, SO_4^{2-}, S^{2-}, Sn^{4+}$ |

Key: 1

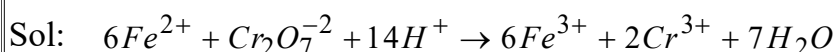

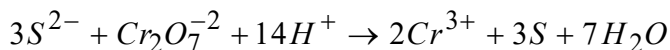
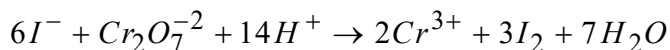
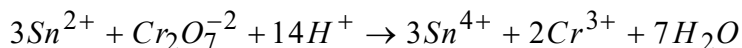

62. Match List – I with List – II

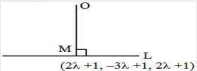
List– I	List– II
Chromium (III) Complexes	Δ_0 (cm^{-1})
(en = ethylene diamine)	
A) $[\text{Cr}(\text{CN})_6]^{3-}$	I) 15060
B) $[\text{CrF}_6]^{3-}$	II) 17400
C) $[\text{Cr}(\text{H}_2\text{O})_6]^{3+}$	III) 22300
D) 	IV) 26600

Choose the correct answer from the options given below:

- 1) A – I, B – II, C – III, D – IV 2) A – II, B – III, C – IV, D – I
 3) A – III, B – IV, C – I, D – II 4) A – IV, B – I, C – II, D – III

Key: (4)

Sol: CFSE is proportional to strength of ligand followed by chelation. CN^- is stronger than en.

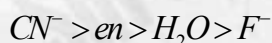

63. Given below are two statements :

Statement-I : 1, 2, 3-trihydroxy propane can be separated from water by simple distillation.

Statement-II : An azeotropic mixture cannot be separated by fractional Distillation

In the light of the above statements choose the correct answers from the options given below

- 1) Both Statement-I and Statement-II are true
 2) Both Statement-I and Statement-II are false
 3) Statement-I is true but Statement-II is false
 4) Statement-I is false but Statement-II is true

Key: (4)

Sol: Glycerol is separated by distillation under reduced pressure

64. Given below are two statements

Statement-I : Benzyl chloride reacts faster in SN^1 mechanism than ethyl chloride

Statement-II : Ethyl carbocation intermediate is less stabilized by hyperconjugation than benzyl carbocation by resonance.

In the light of the above statements choose the correct answers from the options given below

- 1) Both Statement-I and Statement-II are true
- 2) Both Statement-I and Statement-II are false
- 3) Statement-I is true but Statement-II is false
- 4) Statement-I is false but Statement-II is true

Key: (1)

Sol: Rate of SN^1 α Stability of carbocation

Order of stability of carbocation : $Ph - \overset{\oplus}{C}H_2 > CH_3 - \overset{\oplus}{C}H_2$

65. In IUPAC nomenclature, the correct order of decreasing priority of functional group is :

- 1) $-CONH_2, >C=O, -CHO, -NH_2, -C \equiv C -$
- 2) $-CONH_2, -COOCH_3, -CHO, -NH_2, -OH$
- 3) $-CONH_2, -CHO, >C=O, -NH_2, -C \equiv C -$
- 4) $-CONH_2, -CHO, -CN, -NH_2, -C \equiv C -$

Key: (3)

Sol: Functional group priority order is $-CONH_2, -CHO, >C=O, -NH_2, -C \equiv C -$

66. For the given molecule, "x", the preferred site for the attack of the electrophile is :

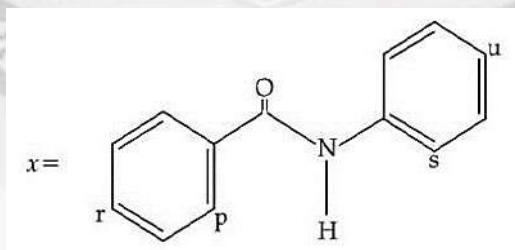

Most preferred site for electrophilic substitution in above example?

- 1) Predominantly at "r"
- 2) "r" and "u"
- 3) "p" and "s"
- 4) Predominantly at "u"

Key: (4)

Sol: u is predominant site towards attack of electrophile because of +M nature of nitrogen.

67. Match List – I with List – II

List – I

Mixture of compounds

A. Diethyl amine + Ethyl amine

B. Acetaldehyde + Acetone

C. Ethanol + Phenol

D. Benzoic acid + Cinnamic acid

List – II

Reagent used to distinguish

I. Bromine water

II. $CHCl_3 + KOH, \Delta$

III. Neutral $FeCl_3$

IV. Ammonical silver nitrate

Choose the correct answer from the options given below :

1) A – IV, B – II, C – I, D – III

2) A – IV, B – II, C – III, D – I

3) A – II, B – IV, C – I, D – III

4) A – II, B – IV, C – III, D – I

Key: 4

Sol: A) Ethyl Amine gives positive test with $CHCl_3 / KOH$ not Diethyl Amine (2^0)

B) Aldehydes gives positive test with Ammonical silver nitrate but not Ketones

C) Phenols gives violet colouration with Neutral $FeCl_3$ but not Ethanol

D) Cinnamic Acid Decolourises the red bromine water where as benzoic acid does not reacts with Bromine water

68. Consider the three aromatic molecules (P, Q and R) whose structures have been given below :

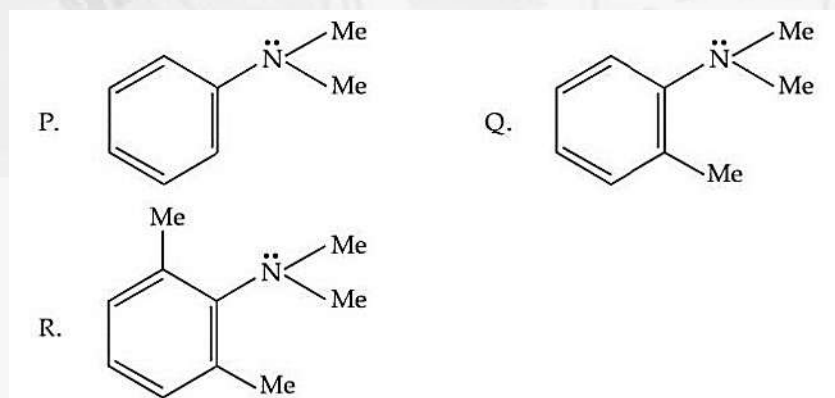

The correct order regarding the reactivity of these compounds with $Ph - N \equiv NCl^{(-)}$
(+)

under optimum but slightly acidic medium is :

1) $P > Q > R$

2) $R > P > Q$

3) $R > Q > P$

4) $P > R > Q$

Key: (1)

Sol: Rate of ESR \propto nucleophilicity of benzene ring, order of nucleophilicity $P > Q > R$

69. Match List – I with List – II

List – I

Vitamin

A) Vitamin B_1

B) Vitamin B_2

C) Vitamin B_6

D) Vitamin C

1) $A - II, B - I, C - III, D - IV$

3) $A - III, B - IV, C - I, D - II$

List – II

Name

I) Pyridoxine

II) Ascorbic acid

III) Thiamine

IV) Riboflavin

2) $A - IV, B - III, C - II, D - I$

4) $A - I, B - III, C - II, D - IV$

Key: 3

Sol: $A - III, B - IV, C - I, D - II$

70. A salt with few drops of conc. HCl gives apple green colour in flame test. The group precipitate of the salt is dissolved in acetic acid and treated with K_2CrO_4 To give yellow precipitate. When the sodium carbonate extract of the salt solution is heated with conc. HNO_3 and ammonium molybdate it resulted a canary yellow precipitate. The cation and anion present in the salt are respectively.

1) Ca^{+2} and SO_4^{2-}

2) Ba^{+2} and PO_4^{3-}

3) Mn^{2+} and PO_4^{3-}

4) Ba^{2+} and SO_4^{2-}

Key: (2)

Sol: i) Ba^{+2} gives apple green colour while Ca^{+2} and Sr^{+2} gives brick red and crimson red in flame test.

ii) $Ba^{+2} + CrO_4^{2-} \rightarrow BaCrO_4$
Yellow ppt

iii) $PO_4^{3-} + Conc\ HNO_3 + (NH_4)_3[P(Mo_3O_{10})_4]$
Canary yellow ppt

SECTION-II
(NUMERICAL VALUE TYPE)

This section contains **5 Numerical Value Type Questions**. The Answer should be within **0 to 9999**. If the Answer is in **Decimal** then round off to the **Nearest Integer** value (Example i.e. If answer is above **10** and less than **10.5** round off is **10** and If answer is from **10.5** and less than **11** round off is **11**).

Marking scheme: +4 for correct answer, 0 if not attempt and -1 in all other cases

71. 5.33 g of $CrCl_3 \cdot 6H_2O$ which is a 1:3 electrolyte, is dissolved in water and is passed through a cation exchanger. The Chloride ions in the eluted solution on treatment with $AgNO_3$ results in 8.61 g of $AgCl$. The ratio of moles of complex reacted and moles of $AgCl$ formed is _____ $\times 10^{-2}$. (Nearest integer)

$$\left[\text{Molar mass in } g \text{ mol}^{-1} \text{ Cr : 52, Ag : 108, Cl : 35.5, H : 1, O : 16} \right]$$

Key: (33)

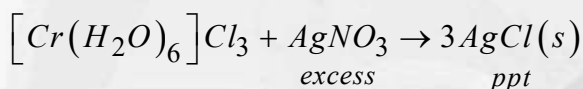

Sol:

$$\frac{\text{number of moles of complex reacted}}{\text{number of moles of } AgCl \text{ precipitated}} \times 100 = \frac{1}{3} \times 100 = 33.3$$

72. Consider the isomers of hydrocarbon with molecular formula C_5H_{10} , these isomers do not decolorise $KMnO_4$ solutions. These isomers are subjected to chlorination with chlorine in presence of light to give monochloro compounds. The total number of monochloro compounds (structural isomers only) formed is _____

Key: (14)

Sol:

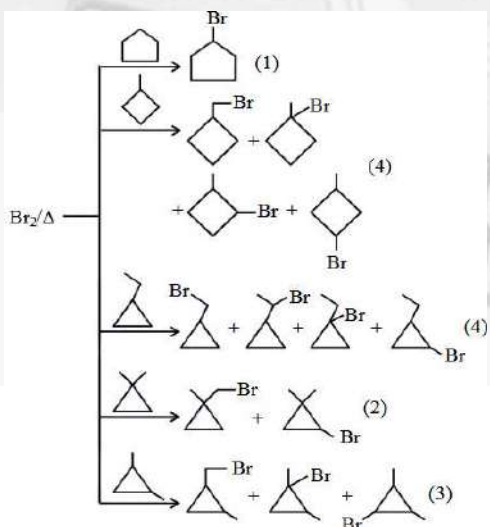

$$1 + 4 + 4 + 2 + 3 = 14$$

73. One mole of an alkane (x) requires 8 moles oxygen for complete combustion. Sum of number of carbon and hydrogen atoms in the alkane (x) is _____

Key: (17)

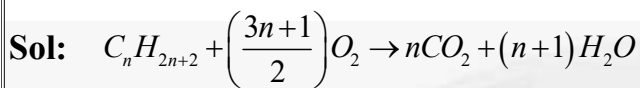

$$\frac{3n+1}{2} = 8 \Rightarrow 3n+1 = 16 \Rightarrow 3n = 15$$

$$n = 5 \text{ So, alkane is } C_5H_{12} \Rightarrow 17$$

74. For reaction $A \rightarrow P$, rate constant $k = 1.5 \times 10^3 s^{-1}$ at $27^\circ C$. If activation energy for the above reaction is 60 kJ mol^{-1} , then the temperature (in $^\circ C$) at which rate constant,

$$k = 4.5 \times 10^3 s^{-1} \text{ is } \underline{\hspace{2cm}}. \text{ (Nearest integer)}$$

$$\text{Given : } \log 2 = 0.30, \log 3 = 0.48, R = 8.3 \text{ JK}^{-1} \text{ mol}^{-1}, \ln 10 = 2.3$$

Key: (41)

Sol: $\ln\left(\frac{K_2}{K_1}\right) = \frac{E_a}{R} \left[\frac{T_2 - T_1}{T_1 T_2}\right]$

$$\ln\left(\frac{4.5 \times 10^3}{1.5 \times 10^3}\right) = \frac{60 \times 10^3}{8.3} \left[\frac{T_2 - 300}{300 \cdot T_2}\right]$$

$$\ln 3 = \frac{60 \times 10^3}{8.3} \left[\frac{T_2 - 300}{300 \cdot T_2}\right] \Rightarrow T_2 = 314.35 \text{ K} \Rightarrow t = 41.2^\circ \text{C}$$

75. At the transition temperature T , $A = B$ and $\Delta G^0 = 105 - 35 \log T$ where A and B are two states of substance X. The transition temperature in $^\circ C$ when pressure is 1 atm is _____ (Nearest integer)

Key: 727

Sol: $\Delta G = \Delta G^0 + 2.303 RT \log k$

$$\frac{\Delta G^0}{RT} = -2.303 \log k$$

$$\Delta G^0 = -2.303 RT \log k$$

$$105 - 35 \log T = -2.303 RT \log k_p \quad (k_p = 1)$$

$$105 - 35 \log T = 0$$

$$105 = 35 \log T$$

$$\log T = \frac{105}{35} \quad T = 10^3 = 1000 \text{ K} = 727^\circ \text{C}$$



Sri Chaitanya
Educational Institutions



TOPPERS ARE NOT BORN, THEY'RE MADE @ SRI CHAITANYA
SEIZES 3 RANKS IN TOP 10 IN JEE MAIN 2025 (ALL-INDIA OPEN CATEGORY)

1
ALL INDIA RANK OPEN CATEGORY
Ajay Reddy Vangala
Appl. No. 250310259592
Classroom Student from Grade IX-XII

1
ALL INDIA RANK OPEN CATEGORY
Devdutta Majhi
Appl. No. 250310018185*

10
All India Rank Open Category
Saksham Jindal
Appl. No. 250310236696*

Secured 31 ranks in Top 100 All INDIA Open Category

12
RANK
SAURAV
Appl. No. 250310254844*

22
RANK
LAKSHYA SHARMA
Appl. No. 250310034153*

31
RANK
BANDARI RUSHMITH
Appl. No. 250310396238

32
RANK
BHAVESH JAYANTHI
Appl. No. 250310269939

33
RANK
UJJWAL KESARI
Appl. No. 250310006860*

36
RANK
PRADISH GANDHI S
Appl. No. 250310788252*

39
RANK
S SAI RISHANTH REDDY
Appl. No. 250310565519

41
RANK
PRASANNA KS
Appl. No. 250310326957

43
RANK
KOLLIBOINA MUNI SAI
Appl. No. 250310488636

44
RANK
GORRE NITHIN REDDY
Appl. No. 250310551436

53
RANK
U RAMA CHARANREDDY
Appl. No. 250310286782

56
RANK
ARNAV NIGAM
Appl. No. 250310026446

60
RANK
SAMUDRA SARKAR
Appl. No. 250310179442*

61
RANK
SOHAN KALIDAS CHELEKAR
Appl. No. 250310202114*

64
RANK
BUDUMURU VIKRAM RAJA
Appl. No. 250310322700

66
RANK
SHAGANTI THRISHUL
Appl. No. 250310500008

70
RANK
LAXIBHARGAV MENDE
Appl. No. 250310248080

71
RANK
D CHETAN RAO
Appl. No. 250310635984

73
RANK
V PRAVAS REDDY
Appl. No. 250310253376

75
RANK
P SAI SURYA KARTHIK
Appl. No. 250310407861

76
RANK
YASH KUMAR
Appl. No. 250310204405*

81
RANK
P PRANAYA SAI MUKESH
Appl. No. 250310608114

89
RANK
ADITYA SINGH
Appl. No. 250310151728

91
RANK
JAY AGARWAL
Appl. No. 250310122371*

94
RANK
V ESWAR KARTHIK
Appl. No. 250310236425

96
RANK
SAKSHAM GARG
Appl. No. 250310026726*

97
RANK
RANVEER SINGH VIRDE
Appl. No. 250310790734

BELOW 100 31 | BELOW 500 95 | BELOW 10 10 | BELOW 100 98 | BELOW 1000 579 | TOTAL QUALIFIED RANKS FOR JEE ADVANCED-2025 22,094



Sri Chaitanya
Educational Institutions



LEADING BY MILES SRI CHAITANYA DOMINATES JEE ADVANCED 2025

29 Ranks in Top 100 in All-India Open Category



4 Students in Top 11 in JEE-Advanced 2025, All India Open Category

16 RANK DEVOUTTA MAJHI HT. No. 255053116*	18 RANK DHARMANA GNANA RUTVIK SAI HT. No. 256055278	19 RANK VANGALA AJAY REDDY HT. No. 256131009	23 RANK AKSH GOGI HT. No. 252071075*	26 RANK P HEMA SAI SURYA KARTHIK HT. No. 256053006	27 RANK SARKARSAMUDRA HT. No. 252071105*
30 RANK DM PRAKASH BEHERA HT. No. 252021018*	32 RANK SUNKARA SAI RISHANTH REDDY HT. No. 256165327	34 RANK DHRUBA JYOTHI PANJA HT. No. 252048248*	35 RANK BHAVESH JAYANTHI HT. No. 251043080	36 RANK ADVAY MAYANK HT. No. 252104113*	37 RANK KARMANYA GUPTA HT. No. 252081477*
42 RANK MD ANAS HT. No. 252046210*	45 RANK RAMIT GOYAL HT. No. 257001113*	52 RANK MAULIK JAIN HT. No. 252079407*	54 RANK GARV HT. No. 252056188*	59 RANK LARISSA HT. No. 252079071*	60 RANK ARYAN BALABADRULLA HT. No. 256132077
63 RANK SAMIYA JYOTI BISWAS HT. No. 255368155*	64 RANK AARUSH ANAND HT. No. 251139707*	72 RANK RUSHMITH BANDARI HT. No. 256189349	78 RANK KORIKANA RASAGNYA HT. No. 256057046	87 RANK LAKSHYA SHARMA HT. No. 252070079*	91 RANK AVANEESH BANGAL HT. No. 251113132*
95 RANK KAVYA AGGARWAL HT. No. 252079121*					

BELOW 100 ALL INDIA OPEN CATEGORY RANKS	29	BELOW 500 ALL INDIA OPEN CATEGORY RANKS	113	BELOW 1000 ALL INDIA OPEN CATEGORY RANKS	205	BELOW 1000 ALL INDIA CATEGORY RANKS COUNT	745	NUMBER OF QUALIFIED RANKS	4,212
-----------------------------------------------	----	-----------------------------------------------	-----	------------------------------------------------	-----	-------------------------------------------------	-----	------------------------------	-------

040 66 15 15 15

www.srichaitanya.net